

SONOREX **Ultrasonic baths**

Instructions for use and applications

Laboratory and process engineering

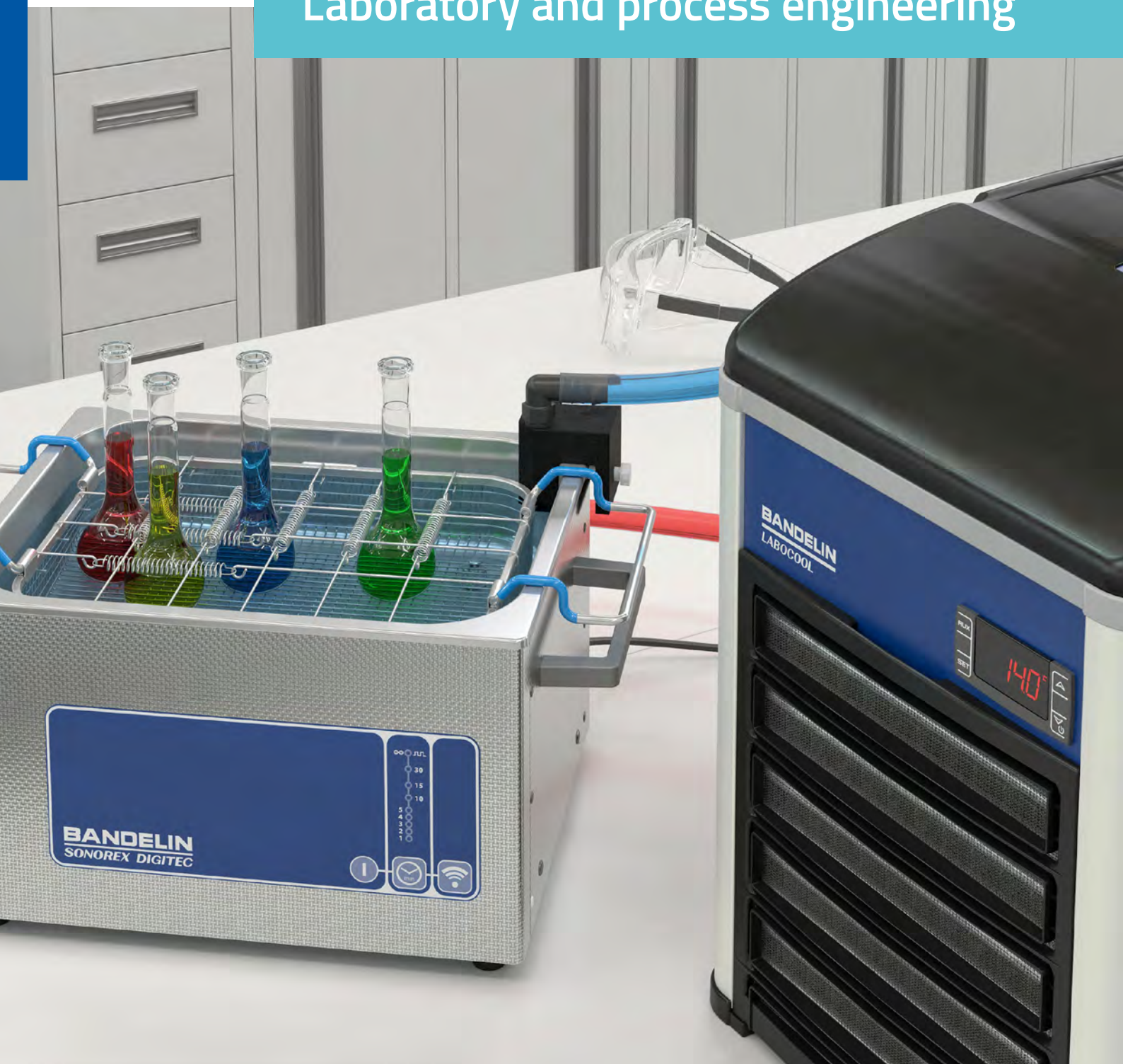

BANDELIN – Specialist of ultrasound in laboratory

SONOREX ultrasonic baths are part of the equipment in every laboratory and are commonly used for cleaning laboratory glassware and other laboratory equipment, for sample preparation for subsequent analysis, and for degassing, homogenising and dissolving samples. BANDELIN offers a wide range of products. An extensive array of accessories supports a variety of applications and facilitates daily routines in the laboratory. The TICKOPUR and STAMMOPUR cleaning and disinfection concentrates, which have been especially developed for the needs of ultrasonic cleaning, have a cavitation-conductive effect and positively influence the material-protecting process.

More than 60 years of product knowledge and experience go into our quality products, which you can rely on. A team of engineers develops the products at our Berlin site and oversees production from start to finish. We can respond quickly to special customer requests.

BANDELIN products meet high standards of reliability and safety. Areas of use include routine laboratory tasks, pharmaceutical research, biotechnology, medical analytics, environmental analytics, petroleum testing and many other applications.

We have developed extensive application know-how thanks to feedback from our customers from a wide range of application areas and above all through our many years of collaboration. Would you like to make full use of our ultrasonic baths' functionality? The application part contains information to help you find the right solution for your application. We are also happy to offer devices with matching accessories for a test run.



BANDELIN – Ultrasound since 1955

Company portrait

We are a family-owned company located in Berlin and meanwhile run in the third generation, specialised in development, manufacturing and sales of ultrasonic devices, the corresponding accessories and application-specific cleaning agents and disinfectants.

A wide vertical range of manufacture, modern production lines and a motivated staff guarantee a high quality of the products. Our devices contribute to the success of our customers in the laboratory, medical, dental, pharmaceutical, industrial, craft as well as service.

As early as 1955, our company began developing and manufacturing high-performance ultrasonic devices. The constant expansion of the product range and a sharp rise in sales led to an expansion of the production area in 1985. In 1992, ultrasonic homogenisers and controllable, power-constant ultrasonic generators were introduced to the market.

The period from 1996 to 2004 was characterised by the development and production of innovative ultrasonic baths and immersible transducers as well as tube reactors for industrial applications. In the following years, BANDELIN's product range was expanded by new laboratory ultrasonic devices.

After the introduction of the ultrasonic bath for simultaneous cleaning and rinsing of MIC instruments, a further development was launched in 2016 for robotic instruments.

Today, the reputation of our brands SONOREX, SONOPULS, SONOMIC and TRISON stand for the high quality awareness of our employees and is equated in expert circles with ultrasound.

The most important product groups include:

- SONOREX – ultrasonic baths and reactors
- SONOPULS – ultrasonic homogenisers
- SONOMIC – ultrasonic baths for rinsable MIC and standard instruments
- TRISON – ultrasonic baths for robotic-, rinsable MIS and standard instruments
- TICKOPUR – cleaning agents
- STAMMOPUR – cleaning agents and disinfectants

We are innovation leaders in the development of ultrasonic devices and new areas of application. In the past we have registered 79 patents / utility models as well as 68 trade brands. Our participation in various committees in the development of new standards and guidelines serve to ensure the highest standards for ultrasonic applications.

As the only complete supplier of ultrasonic devices, accessories, disinfectants and cleaning agents with approvals and certifications according to ISO 9001 and ISO 13485, BANDELIN is the market leader.

Over one million units have already been delivered to our customers.

1955



SONOREX E 250-12
Production of high-power ultrasonic cleaning devices

1971



SONOREX TRANSISTOR RK
Ultrasonic baths with transistor technology

1990



SONOREX DIGITAL DK
Digital ultrasonic baths

2008



SONOSHAKE
for sample preparation

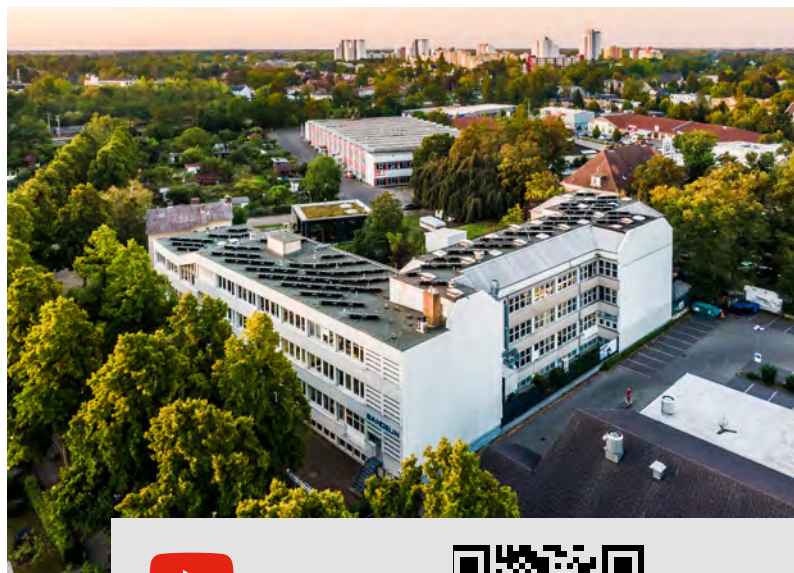

Our Company portrait
Laboratory
[youtube.com/bandelin](https://www.youtube.com/bandelin)



2010



BactoSonic
Ultrasonic special bath for gentle removing of biofilms



SONOCOOL
Ultrasonic bath with cooling

2013



SONOREX DIGIPLUS DL
Digital ultrasonic baths with power control

2022



LABOCOOL
Recirculating Chiller

Content

BANDELIN – Specialist of ultrasound in laboratory	3
BANDELIN – Ultraschall seit 19554	4
1 • Ultrasound in the laboratory and in process engineering	8
What is ultrasound? How does it work?	10
Influencing factors of the ultrasound process	11
Advantages of ultrasonic cleaning.....	11
Quick Start – for use of the device in laboratory	12
Structure of an ultrasonic bath.....	14
Decisive parameters for the power density in ultrasonic baths.....	16
Selection criteria for the ultrasonic bath	17
2 • SONOREX Ultrasonic baths – Applications	20
Overview of applications.....	20
3 • SONOREX Ultrasonic baths in compact design.....	28
Advantages of SONOREX compact baths at a glance	28
SONOREX – Control	
Ultrasonic baths in three versions.....	32
SONOREX SUPER RK.....	32
SONOREX DIGITEC DT.....	33
SONOREX DIGIPLUS DL.....	34
The variants – in comparison.....	35
Bath sizes and technical data.....	36
Application-specific accessories	40
Accessories for the process technology	42
Configuration examples	44
SONOREX Accessories.....	46
4 • Ultrasonic bath for special requirements	50
SONOREX DIGITEC ... F Ultrasonic baths with flat oscillating tanks	52
SONOSHAKE Set Ultrasonic baths with shaking device	54
LABOCOOL LC 400 Recirculating chiller.....	56
SONOREX PR 140 DH Ultrasonic bath for the cleaning of volumetric glassware	60
SONOREX Ultrasonic baths for the cleaning of analysis sieves.....	62
SONOCOOL Ultrasonic bath with cooling	64
BactoSonic Ultrasonic bath for gentle removing of biofilms	68
5 • Agents for cleaning and disinfection	72
TICKOPUR and STAMMOPUR.....	74
Shelf life of disinfectants and detergents	80
Dosage calculator	80
FAQ – Agents.....	81
6 • Service – We are the specialists for ultrasound in laboratory	82
Ultrasonic baths for rent.....	84
KNOWLEDGE.....	86
Detailed application examples.....	90
FAQ - Ultrasonic baths	101
Your contact person for the laboratory field	102

Ultrasound in the laboratory and in process engineering



**Quick start – for use
of the device in laboratory**

The most important steps for a
quick start with the
SONOREX ultrasonic bath.

[from page 12](#)

01



What is ultrasound? How does it work?

Short introduction to the basics
and how ultrasound works.

page 10



Influencing factors of the ultrasonic process

The most important aspects
for a perfect result.

page 11



Advantages of ultrasonic cleaning

The intensive cleaning effect
is not the only advantage.

page 11



Structure of an ultrasonic bath

Basic structure including
explanation of individual components.

from page 14

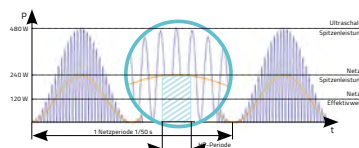

Power density in the ultrasonic bath

Explanations of the
decisive parameters.

page 16



Selection criteria of an ultrasonic bath

Small guide to finding the perfectly
suitable ultrasonic bath.

from page 17

What is ultrasound? How does it work?

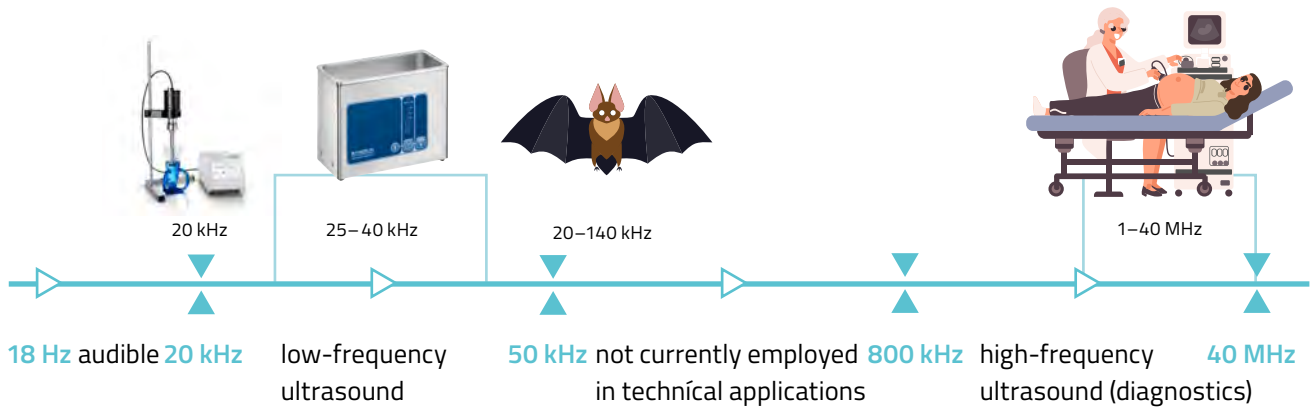

What is ultrasound and how does it work?

Oscillations with frequencies above 18 kHz (18,000 oscillations per second) are referred to as ultrasound. Low-frequency ultrasound is used in laboratories whilst a higher frequency range is used for medical diagnostics.

The low-frequency ultrasonic oscillations result in the generation of millions of tiny vacuum bubbles in all liquids, which then implode immediately generating highly effective pressure surges. This process is called cavitation. Low frequencies of around 20 kHz create bubbles with larger diameters and more intensive pressure surges than compared with frequencies of around 35 kHz. Low-frequency ultrasound has been used in a wide range of ultrasound baths for decades.

The cavitation process effectively and gently removes residual dirt from the surfaces of components immersed in the fluid as well as out of recesses and holes. Other applications include the degassing and mixing of liquids.



Cleaning with a SONOREX ultrasonic bath from BANDELIN
[youtube.com/bandelin](https://www.youtube.com/bandelin)



Cavitation

Ultrasound creates an intensive pressure-pull change in aqueous liquids, resulting in very fine cavitation bubbles that grow over several cycles and then implode intensively. The resulting high shear forces and microjets of the implosions blast off all adhering contamination from the surface in a short time.

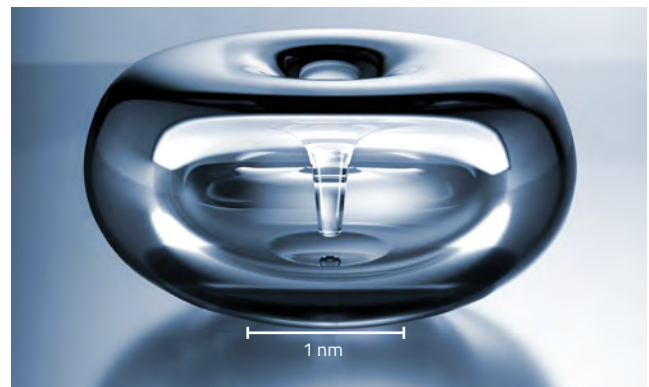

Cavitation bubble

Influencing factors of the ultrasound process

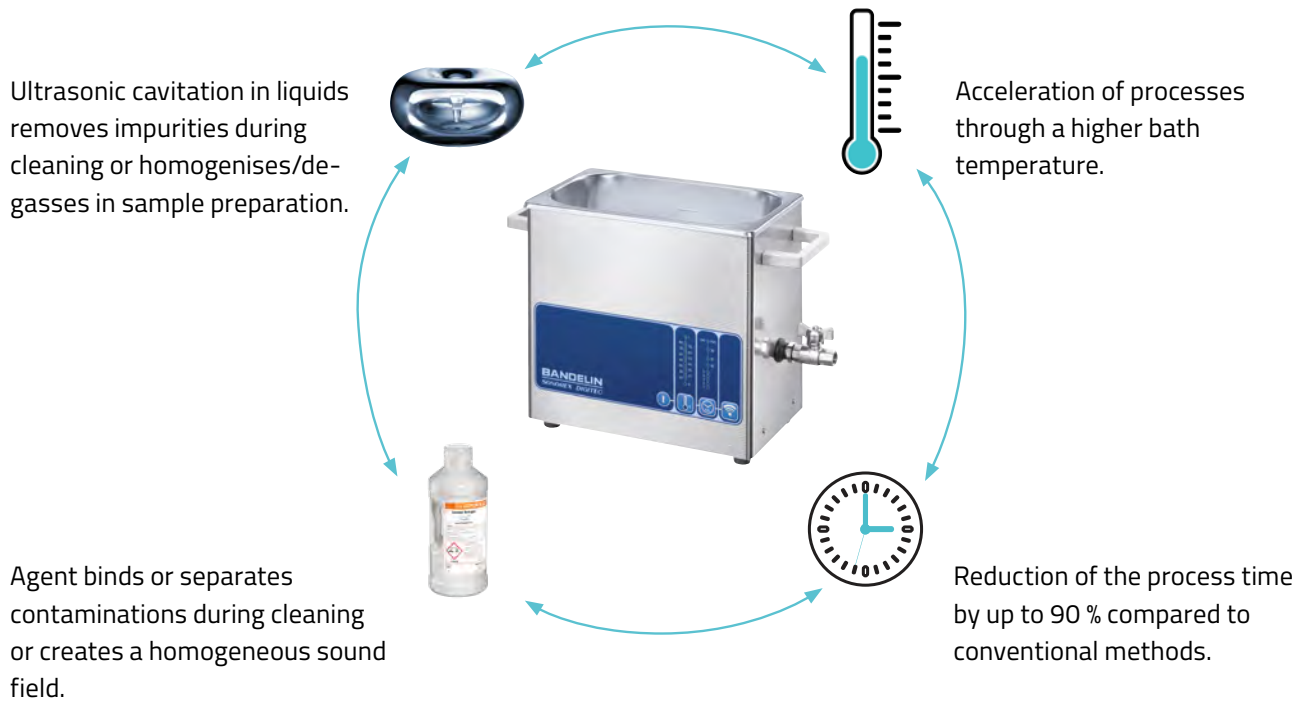

Advantages of ultrasonic cleaning

The use of ultrasonic baths for cleaning in a wide variety of applications has become so widespread because it combines a multitude of advantages.

 <p>Cleaning effect</p> <ul style="list-style-type: none">▪ Efficient▪ Gentle	<p>Environment</p> <ul style="list-style-type: none">▪ No use of organic solvents▪ Surfactants contained in the TICKOPUR/STAMMOPUR agents are biodegradable according to the Detergents Regulation. 
 <p>Time</p> <ul style="list-style-type: none">▪ Up to 90 % shorter cleaning time▪ Reduced costs	<p>User-friendly</p> <ul style="list-style-type: none">▪ Easy to install and operate▪ Maintenance-free 



Quick start – for use of the device in laboratory

Proper handling and regular care can counteract rapid wear and thus extend the service life of the ultrasonic bath.



1



Preparation for operation of the ultrasonic bath

- a. See instructions for use.

2



Selection of accessories to suit the application

- a. The selection of accessories depends on the object to be treated and the application.
- b. Selection of the method: direct or indirect sonication

Note: The sonication object may not be placed directly on the tank bottom!

3



Selection of the cleaning agent

- a. Adapted to the application: Cleaning and/or disinfection or contact liquid for indirect sonication
- b. Determine correct concentration. Use our dosing table and our dosing calculator (www.bandelin.com/service/dosierechner) and observe the product information for the cleaning agent.

Note: BANDELIN offers a wide range of agents specifically developed for ultrasonic cleaning, TICKOPUR and STAMMOPUR.

4



Filling the ultrasonic bath

- a. Filling the bath with tap water or demineralised water together with the appropriate agent

Notes: Observe the filling level mark. The fill level may not fall below the mark. Keep in mind that the inserted object or inset vessel may displace the bath liquid and the bath may overflow.

Filling an
ultrasonic bath
[youtube.com/bandelin](https://www.youtube.com/bandelin)



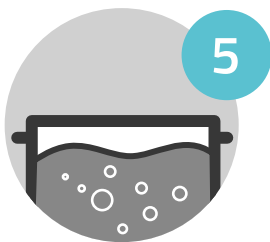

5

Degassing the bath liquid

Remove the dissolved gases by switching on the ultrasound or using the DEGAS function (for SONOREX DIGITEC DT/DL). Degassing is necessary with freshly prepared bath liquid or bath liquid that has not been used for a long period of time.

Guideline values for degassing times:

Bath volume up to 10 l: approx. 10 mins

Bath volume > 10 l: approx. 30 mins

Degassing a SONOREX DIGITEC DT 102 H ultrasonic bath
[youtube.com/bandelin](https://www.youtube.com/bandelin)



6

Introduce the goods to be treated

- a. Insert the sonication object into the insert basket, the rack, the inset beaker

Notes: Cleaning objects must not be allowed to overlap. Parts with joints must always be opened before insertion. No air-filled cavities may form.

The object to be cleaned must be completely covered with the cleaning liquid.



7

Setting the sonication parameters

Set the sonication time, temperature (only for devices with heating) and ultrasonic power (for DIGIPLUS only)

- a. based on your own experience or
- b. according to the instructions for use or the product information for the agent.

Note: Temperature – cooling

Some processes, such as the homogenisation of samples in the pharmaceutical field, require a constant temperature. In this case, an external cooler is always required to reduce the heat generated. We recommend our LABOCOOL 400.



8

Starting the application

Notes: For temperature-sensitive goods, the bath temperature should always be checked as it increases even without additional heating. The energy introduced by the ultrasound heats up the cleaning liquid.



9

Completing the cleaning process

- a. Rinse the objects to be cleaned thoroughly and, if necessary, carry out further reprocessing steps
- b. Maintenance of the ultrasonic bath (observe instructions for use)

Structure of an ultrasonic bath

Ultrasonic baths perform a variety of tasks in everyday laboratory life. The variety of devices on offer is accordingly diverse. Understanding the basic structure of an ultrasonic bath and the resulting application-related selection of equipment features and application parameters, is the basis for a successful application.

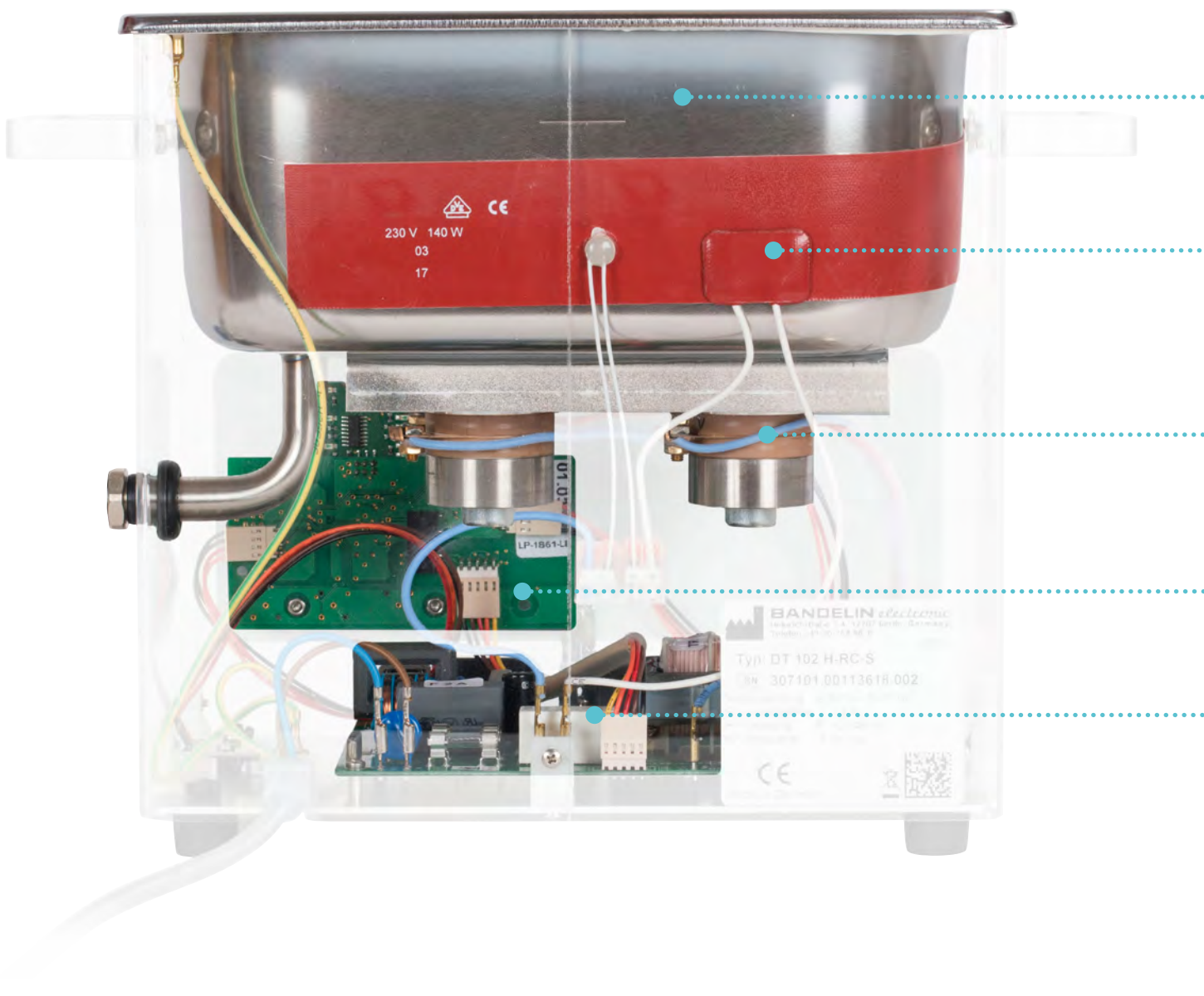

Oscillating tank

Stainless steel 1.4301 (stamped),
SONOREX RK/DT 102 H: additionally hard chrome plated
or partially stainless steel 1.4404 (welded),
thickness 2 mm

Heating

Surface heating elements; automatic switch-off against
overtemperature.

Oscillating systems

Transforming the high-frequency voltage supplied by the
generator using piezoelectric converters into mechanical
resonate oscillations of the same frequency.

The connection between the oscillating systems and the
stainless steel tank is realised with a high-strength ad-
hesive process.

The decisive factor for understanding is that the dimen-
sions of the vibrating elements determine the operating
frequency.

Once the dimensions have been defined, the operating
frequency can no longer vary. The number of vibrating
elements determines the power in the bath.



Control unit

Preselecting the process parameters time and/or tempe-
rature or DEGAS or power.

Ultrasonic generator

Transformation of inputted low-frequency mains energy
of 50/60 Hz into high-frequency voltage of 35 or 40 kHz.

Decisive parameters for the power density in ultrasonic baths

The power density in W/cm^2 can only be determined on the active sound-emitting surface, i.e. the surface of the transducers. However, since the entire tank oscillates, the reference value for the calculation is missing here. Therefore, the power density is always stated in W/L . The power density is determined from the nominal/effective power [W] and the filling volume:

$$\text{Power density [W/l]} = \frac{\text{Nominal/effective power [W]}}{\text{Filling volume[l]}}$$

The ratio of power to filling volume is often not identical in different baths. A large filling volume usually results in lower power densities, especially in large baths. This means that the results in a small bath cannot necessarily be carried over to a large bath. This is important information for laboratory applications, because baths are often used for applications that are basically identical, but have varying volumes.

What do the following statements mean?

- Ultrasonic power – 100 W effective
- Nominal/effective power – 100 W
- 2 x 200 W continuous peak power
- 400 W ultrasonic peak power

Most manufacturers state the peak value in the technical data. This value is of little significance, however, as the ultrasonic baths usually work in double half-wave operation. Therefore, both the continuous peak power and the ultrasonic peak power are based on the same nominal/effective value. This value should therefore be used to select the most suitable ultrasonic bath.

Important!

Only the nominal/effective value, in relation to the filling volume of the oscillating tank, is the decisive factor!

If the nominal/effective value is missing, ask for it!

Ultrasonic peak power in double half-wave operation

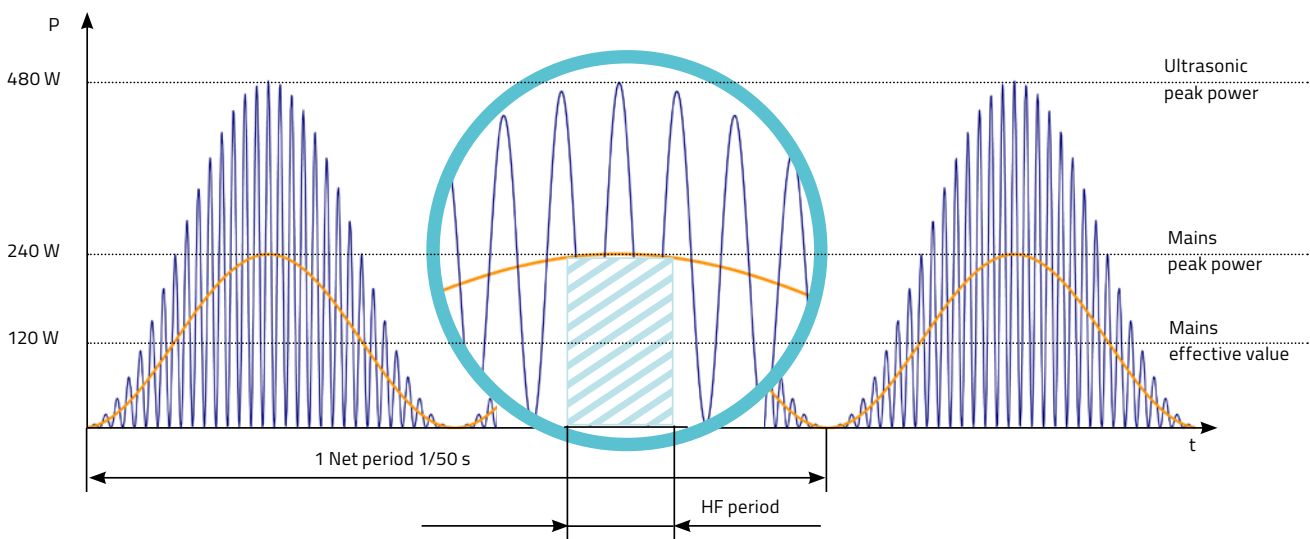

Selection criteria for the ultrasonic bath

An optimal sonication result is achieved by selecting the ultrasonic bath that is most appropriate for the application, with suitable accessories for holding the objects. Equally important, however, is the optimal selection of the agent, whether for the cleaning effect or for generating a homogeneous sound field in the bath.

With TICKOPUR and STAMMOPUR, BANDELIN offers an extensive range of cleaning agents and disinfectants.

Size of bath

The selection of the appropriate bath size depends on the applications and the items to be cleaned or the size of the sonication vessels. First and foremost, it is crucial that the objects to be treated are integrated in the corresponding accessories, e.g. insert basket, utensil holder. The ultrasonic bath is selected on this basis. BANDELIN manufactures ultrasonic baths for laboratories from 0.9 to 90 l.

It is not the specified content [l] that is decisive, but rather the space requirement of the object.

For example, an ultrasonic bath with a small footprint and a higher bath depth can have the same bath volume as a flat ultrasonic bath with a larger footprint.

The objects must be completely covered with the liquid during cleaning. They should be prevented from overlapping so that the effect of the cleaning liquid can fully develop in combination with the ultrasound.

In the case of indirect sonication, the vessels must be immersed in the contact liquid by at least 2 cm so that the ultrasound is transferred to the vessels' cleaning liquid.

If different ultrasonic applications are to be performed with the bath, make sure that the ultrasonic bath is suitable for every application. It is possible to save significant time by carrying out several applications in one operation.

Other aspects include the space requirement of the device on the work surface and the installation conditions.



From front to back: DT 31 H, DT 100 H, DT 102 H and DT 255 H

Type of sonication

Direct sonication

With this method, simple and effective sonication of the parts (e.g. during cleaning), is possible. The cleaning solution is dosed directly into the oscillating tank, while the parts are either placed in the insert basket or hung in the oscillating tank using an appliance, without touching the tank bottom. In the latter case, the entire capacity of the oscillating tank can be used. The loosened contamination collects on the bottom. For example, metal shavings accelerate the erosion process. The impurities should be removed regularly to protect the oscillating tank.

Tap water with cleaning additive should always be used. With the otherwise high surface tension, the parts surface is not sufficiently wetted and the contamination can only be removed inadequately.

Ensure that the dosage is correct. To do so, use the filling level mark in the bath, the dosing table and dosing aids (faucets and pumps) for the agents.

The first rinse can be performed with drinking water.

Distilled/deionised water is recommended for the second and third rinses after cleaning, to remove the cleaner and contamination residues in order to prevent staining. In addition, any salt residues are rinsed off. This is important for cleaning of PC boards.



Indirect sonication

The oscillating tank is filled with water and an ultrasound-compatible cleaning agent (= contact liquid) to promote cavitation. The ultrasound is transferred to the liquid in the vessel via the contact liquid.

For liquids that are not to be used directly (e.g. acids, solvents), insert tubs made of plastic or inset beakers made of glass, stainless steel or plastic are used.

Indirect use is also recommended if different cleaning solutions are to be used in the inset beakers. This means that the cleaning liquid is not discarded immediately when changing to another preparation. Different types of parts can also be cleaned at the same time. The contamination remains in the inset beaker.

In the case of sample preparation, the sample vessels for homogenisation, extraction or dissolution are placed in the insert basket and sonicated via the contact liquid.



Accessories

Choosing the right accessories is crucial for application success.

BANDELIN offers a wide range of accessories that are optimally adapted to requirements and can be used flexibly.

The object determines the type of sonication (direct or indirect) and the choice of accessories. The objects to be cleaned or the sonication vessel may never be placed directly on the tank bottom so that they and the object are not damaged (see Fig.).

For small parts, gentle cleaning in a beaker is recommended. In addition, special accessories make the application process and application success easier. Often, a larger number of objects can be sonicated in this manner. This ensures a higher throughput rate and thus an efficient working day.

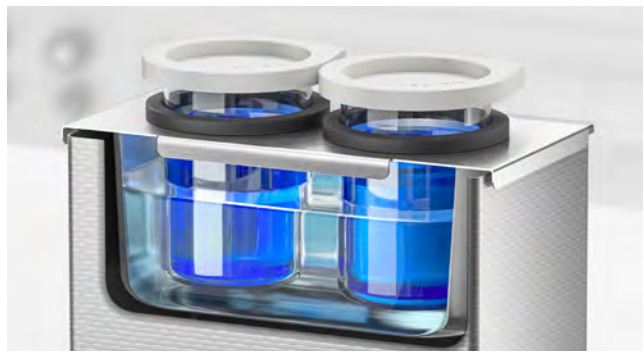

Ultrasonic baths with and without heating

In all ultrasonic baths with heating, this feature can be switched on. This means that the bath liquid can be heated or the heating can remain deactivated, depending on the application.

Cleaning processes or even the dissolving of substances, etc., can often be accelerated through an increased temperature. This is essential for removing greasy or oily impurities. Ultrasonic baths with heating must therefore be used for these applications.

The heating power is adapted to the size of the bath. These values can be used to determine how quickly the liquid heats up with a certain bath volume.

However, it is necessary to ensure that additional heating is also carried out by the ultrasound – the sonicated liquid is heated up through cavitation.

Ultrasonic baths with heating in the SONOREX DIGITEC series feature temperature monitoring. A temperature range between 20°C and 80°C can be set. For example, if the set temperature of 25 °C is exceeded in an application with a temperature-sensitive part or sample, this will be indicated by the red warning LED lighting up.

The user does not need an external temperature measuring device and can intervene in the process in a timely manner.



Function Degassing

For ultrasonic baths with digital controls, the "DEGAS = rapid degassing" mode can be selected separately. An impulse sound, a continuous ON/OFF mode, is initiated.

In Off mode, the gas bubbles are given time to rise more easily and degassing can thus be achieved at a much higher speed.

Function Sweep

SweepTec is a special frequency modulation (sweep) around an optimally set operating point that prevents load-dependent vibrations. This results in very fast frequency changes of approx. ± 1 kHz after every 10 ms. This leads to a reduction of standing waves in the bath and thus to a homogeneous sound field.

A particularly homogeneous ultrasound field prevents damage to very sensitive parts.

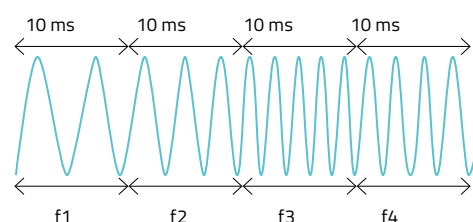

SONOREX Ultrasonic baths – Applications

02



Overview of applications

Presentation of various processes and working areas for ultrasonic applications.

[from page 22](#)

Overview of applications

The number of possible applications is very large and the application areas are especially broad: Environmental analytics, toxicology, food and beverages, cosmetics, chemicals and pharmaceuticals, the building materials industry, biology, microbiology, life sciences, human medicine.

New applications are constantly being added. There is hardly a single laboratory that does not use an ultrasonic bath. The most common applications and industries in which ultrasonic baths are used in the laboratory are listed here. Regard it as inspiration for your own situation, in which ultrasonic baths might be a viable solution.

Cleaning

By far the largest area of application for ultrasonic baths is the cleaning of parts, instruments, etc. The cavitation effect blasts contaminants off of parts submerged in the liquid and even removes them from recesses and drilling holes. Ultrasound combined with the corresponding cleaning agent cleans in just a few minutes and surpasses any manual cleaning in terms of effectiveness. At the same time, it has a more gentle effect as it causes no mechanical damage such as scratches.

Cleaning glassware and other small parts

Glass, components of machines or devices, etc. can be perfectly cleaned using ultrasound. Selection of the appropriate agent additive is particularly important for this purpose.

For instance, trace analytics often used solvents for detailed cleaning in the past. Nowadays, ultrasonic baths and a suitable aqueous cleaning agent are the alternative and they help to improve the environmental balance at the same time.

There are no limits to the imagination when it comes to which cleaning tasks can be successfully performed with the ultrasonic bath.

Examples are:

- Cleaning of glass vessels for trace analytics
- Glass pipettes and burettes (see chapter 04)
- Cleaning of capillaries, electrodes, etc.
- Cleaning of glass fermenter parts for complete removal of biofilms and also stuck material after autoclaving, such as on reactor stirrer shafts
- Cleaning of loops for crystallizing proteins in the Life Science Crystallization Lab
- Cleaning of quartz glass or parts made of PTFE for trace analysis to remove sawdust
- Cleaning of clogged small parts in paper machines
- Cleaning of mass spectroscopy sources, etc.

Nowadays, a large number of laboratories is equipped with devices to perform liquid chromatography with mass spectrometry coupling (LC-MS for short), to separate and identify molecules. The combination of liquid chromatography and mass spectrometry is a common analytical procedure for this purpose. Parts of such equipment require regular cleaning to ensure a trouble-free operation and reproducible analytic results. An ultrasonic bath is excellent for such cleaning and is used this way in almost all laboratories where such techniques are performed. In some cases, several cleaning steps are carried out indirectly – i.e. in the inset beaker – one after the other, such as:

1. Water/methanol/1–3 % formic acid
2. Methanol
3. Isopropanol

In other cases, cleaning is performed in water at 60–70 °C for 30 min.



Cleaning of analysis sieves

Sieve analyses are carried out in numerous fields of application, often for the sample preparation of analyses such as grain size determination. Analysis sieves are measuring instruments and should therefore be handled carefully before, during and after use.

Sieves with mesh sizes of under 500 µm, in particular, should generally be cleaned in only an ultrasonic bath.



Areas of application:

- Quality assurance and monitoring of disperse bulk solids, usually as sample preparation for the analytics
- Sieve analysis of silver powders in metal processing
- Sieving of ashes containing precious metals in metal processing
- Sieving of sediments and soil material
- Sieving of ground samples (soil, clay)
- Sieving of baking agents and chocolate in the food industry



Degassing and Defoaming

The removal of air or other gases from liquids is essential for further use in a variety of scenarios, for example for HPLC eluent, for the analysis of sparkling drinks, for the degassing or defoaming of emulsions, varnishes, etc.

Degassing or defoaming with an ultrasonic bath is very fast, simple and effective. A special degassing mode (DEGAS) can be selected for the digital ultrasonic baths, which enables much faster degassing of the liquid.

Examples of applications:

- Degassing of HPLC solvents to avoid analysis problems caused by air bubbles in the chromatography column and to extend the life of the solvents – less algae growth after oxygen removal, etc.
- Degassing of mineral water, beer, cola, champagne, etc. for analytics, e.g. for the determination of oligosaccharides via HPLC in beer, determination of potassium in mineral water via AAS, for heavy metal ion analysis via ICP
- Degassing/deaerating of lotions, shampoos, hair conditioners, etc. in analytics
- Degassing of molasses samples in analytics



Degassing of beer with a SONOREX ultrasonic bath
[youtube.com/bandelin](https://www.youtube.com/bandelin)



Dissolving of substances

Ultrasound can also significantly influence the dissolution processes of solids. They are accelerated and, in some cases, allow a significant dissolution of a solid until the solubility product is attained. The use of ultrasound supports the analysis of substances from a very wide range of areas and media (food, environment, materials, life science, etc.) and other processes in the laboratory environment.

Ultrasound treatment is often used in the following applications:

- Dissolution of salts or bases such as sodium hydroxide for buffers or other applications
- Dissolution of standard and reference substances for a variety of analytical methods
- Dissolution of sample material in extraction agents or similar, for sample preparation for analytics
- Dissolution/homogenisation of liquid creams, lotions, shampoos, hair conditioners or similar as sample preparation for analytics
- Dissolution of tablets without mortars (prevention of carryover in the case of confiscated tablets)
- Dissolution of natural substances, drug substances, and chemicals that are difficult to dissolve, both organic and inorganic, such as Cu-glycine complex or similar.
- Dissolution of reference substances from PCBs, PAHs, etc.
- Dissolution of small molecules or biopeptides for solubility and stability studies in the pharmaceutical sector
- Dissolution of lipids or poorly soluble peptides for HPLC analysis

- Dissolution of saccharin standards, preservatives, etc.
- Resolubilisation of dry extracts or similar for analysis, e.g. reuptake in MS-capable solvents for LC-MS analysis
- Reuptake of dried extracts after solid phase extraction for analysis of drug substances in water

In addition, there is a large number of special use cases to support the solution process by means of ultrasound.

In any case, a test is worthwhile unless physical limitations cannot be overcome.

If the desired results have not yet been achieved, the test with the SONOPULS ultrasonic homogenisers is recommended, as the energy input into the sample matrix with the liquid is significantly higher (up to 3000 W/L compared to up to 50 W/l in the ultrasonic bath).

Please refer to the corresponding application guide

“SONOPULS Ultrasonic

Homogenisers – Use and applications” for additional information, or contact us for a consultation

and a three-week free trial.

The ultrasonic homogeniser has established itself this way. The dissolution of nano-materials that are difficult to dissolve is one example.

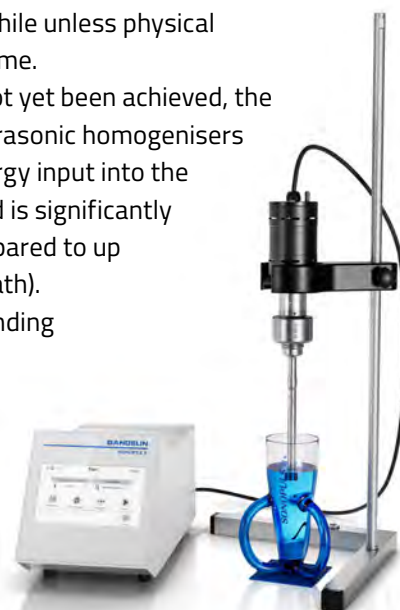

Extraction of solid substances in a liquid medium

Support for the extraction of ingredients from solid particles in the liquid phase represents yet another, extremely interesting field of application. This is often a necessary step in sample preparation for the analysis of ingredients from food, environmental media, materials, commodities, plants, etc.

The advantages to be achieved for many applications, in comparison to other extraction methods, are the following:

- Higher yield
- Reduced extraction time
- Lower required temperature
- Lower proportion of solvents or complete conversion to aqueous phases

In some cases, a combination of ultrasound and other extraction methods makes sense. The application can be individually adjusted to the requirements and can be easily upscaled to production processes.

In the environmental field, the extraction of organics (PAHs, PCBs) from soil and waste has established itself in recent years as a substitute for Soxhlet extraction. In parallel tests with Soxhlet extraction and in interlaboratory tests by the BAM (Federal Institute for Materials Research and Testing), the equivalence of the extraction results was verified. The method is now established in the industry. As a result, considerable quantities of solvents are saved; extraction with ultrasound is possible in a shorter time, max. 1 hour.

Some examples of applications that have been established for years:

- Extraction of drugs from hair, for hair analysis for cocaine
- Extraction of cheese for the analysis of water-soluble substances
- Extraction for enzymatic sugar analysis in water/methanol
- Extraction of PAHs from strawberries to prepare the determination of the pollutant load
- Dissolution of the analyte-matrix binding in milk to monitor penicillin contents
- Extraction for sample preparation of the screening for pesticides and other residues in food for analysis via LC-MS, etc.
- Extraction of analytes from soil and waste in different solvents for analysis via GC and HPLC
- Extraction from soil, water, asphalt, drill cores, tar, paint and varnish residues in various solvents for residue analysis of PAHs, PCBs, MOHs
- Extraction of compounds typically found in explosives, from the soil
- Extraction of PCBs from wood preservatives
- Extraction of analytes from wipes with which environmental pollutants have been picked up from surfaces
- Rapid elution of pollutants from soil and waste – in parallel to the determination of extractable organically-bound halogens as per DIN 38414, for example.
- Extraction of pollutants from plaster, wallpaper, joint materials and similar in the area of building pollutants, in various solvents such as hexane, hexane acetone, dichloromethane
- Extraction of quaternary ammonium compounds from treated wood (part of wood protection)
- Extraction of analytes from cardiac muscle tissue, animal tissue, etc.
- Extraction of analytes from dry blood matrix for LC-MS in clinical chemistry
- Extraction of analytes from seeds, flour, baked goods
- Extraction of phytonutrients from dried, pulverised plants
- Homogenisation of ointments and pharmaceutical raw materials, etc., as sample preparation for HPLC
- Homogenisation of gastric contents for the analysis of tablet residues in toxicology



Disagglomeration

Agglomerates of substance particles can be effectively destroyed via ultrasound. This is used, for example, in sample preparation for particle size analysis.

Application example:

- The disagglomeration of particles in ground samples (soil, clay) or other sample matrices from the environmental and pharmaceutical fields; for analysis by means of AAS, ICP, NMR, IC to prevent analysis influences due to aggregate formation



Alternative acid digestion methods

Classic digestions often take place at elevated pressures and temperatures above 100 °C in order to attain the necessary energy input. Alternative methods are often possible and allow for the energy input to be realised by ultrasound, which also saves time. The process is also safer because it avoids high pressures.

Application example:

- Disruption for mercury determination in water and wastewater by means of AAS according to DIN EN ISO 12846:2012-08



Cell disruption – disagglomeration of cells and similar

Agglomerates can be effectively destroyed by means of ultrasound. This applies not only to solid substances but also to cell agglomerates, for example as preparation for cell count determination in microbiology.

In the ultrasonic bath, the lysis process (cell disruption through the addition of chemical detergents) is often supported.

Application examples:

- Isolation of DNA from soil samples using chemical lysis (according to Porteous et al., 1994)
- Disruption of mammalian eukaryotic cells with chemical detergents (lysing)
- Dispersion/disagglomeration of cells from fermentation for correct cell counting

Complete disruption of cells can be achieved with higher energy input. The SONOPULS ultrasonic homogeniser has established itself for this purpose.



Other laboratory applications

In addition to these main applications, ultrasonic baths are also used for a variety of special tasks in which the special effect of the ultrasound can be used time and again for the desired result. Again, here are a few examples illustrating the wide range of possibilities:

Chemical-physical field

- Within the scope of air analytics – desorption of analytes from adsorption materials – silica gel in acetonitrile
- Washing/decontamination of hair samples before actual extraction of hair ingredients for drug analysis
- Support for derivatisation of high-boiling substance samples for analysis using GC-MS (previously very common and important, nowadays less so due to

the widespread replacement of such analysis by LC-MS)

- Removal of salts applied to paper within the scope of paper tests
- Columns of W/O emulsions

Life Sciences

- Resolubilisation of samples after PCR for MS
- Removal of proteins and peptides from the gel using electrophoresis

Building materials industry

- Determination of the frost-thawing salt resistance of concrete in accordance with DIN 4246: Ultrasonic treatment of the test specimens as sample preparation

Practical application tips from our laboratory partners are summarised in detailed application examples in a tabular overview from page 90 up to page 100.



SONOREX

Ultrasonic baths in compact design

03



Advantages of SONOREX compact baths

Tangible arguments for an ultrasonic bath from BANDELIN.

from page 30



SONOREX SUPER RK

The most important features of operation and functions.

page 32



SONOREX DIGITEC DT

The most important features of operation and functions.

page 33



SONOREX DIGIPLUS DL

The most important features of operation and functions.

page 34



SONOREX model variants in comparison

Practical overviews of all key data of our three versions.

page 35



SONOREX bath sizes and technical data

Overview of the device series SUPER RK / DIGITEC DT / DIGIPLUS DL

from page 36



SONOREX accessories and configuration examples

Combine our accessories exactly for your applications.

from page 40

Advantages of SONOREX compact baths at a glance



SONOREX SUPER RK 102 H



SONOREX DIGITEC DT 102 H



SONOREX DIGIPLUS DL 102 H

Long lasting design

- Compact, easy-care stainless steel housing
- oscillating tank:
 - made of stainless steel AISI 304 (drawn)
- SONOREX RK/DT/DL 102 H:
 - additionally hard-chrome plated
- partly stainless steel AISI 304 (welded),
- 2 mm material thickness
- High-performance oscillating systems, manufactured with highly stable ceramic piezoelectric materials
- Made in Germany



MADE IN
GERMANY



Rounded tank corners

On the sides and bottom; facilitate cleaning of the oscillating tank. For hygienic handling of the ultrasonic bath.



Filling mark level

As an easily recognisable embossing for the minimum filling level of the cleaning liquid; facilitates filling.

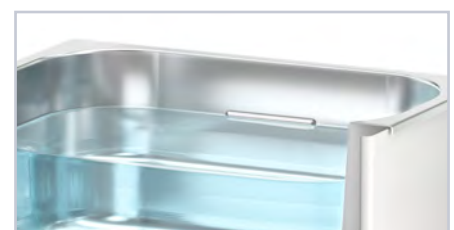



Welded outlet

With ball valve for emptying the ultrasonic bath (from RK/DT/DL 102 H).

The outlet bend is welded to the bottom of the tank and not screwed. This prevents leaks in the appliance and makes cleaning easier.

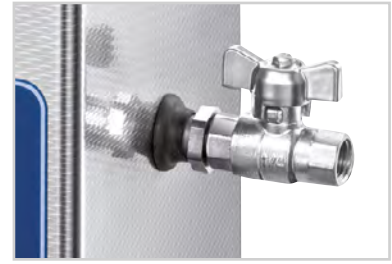

Fixed power cable

In contrast to the usual plugged-in mains cables, these are permanently installed in SONOREX ultrasonic baths. This eliminates the risk of liquid penetration at this connection and the associated risk of a short circuit.



Device feet (plastic)

For secure standing on any surface.



Handles

For easy and safe handling (excluding RK/DT 31, RK/DT 52, RK/DT 100, RK/DT 103 H, RK/DT 106, RK/DT 156, RK 170 H, RK 1040).



Heating

Depending on the model, with integrated heating. Adjustable temperature ranges:

- RK: 30–80 °C, excluding RK 31 H: 65 °C fix
- DT/DL: 20–80 °C

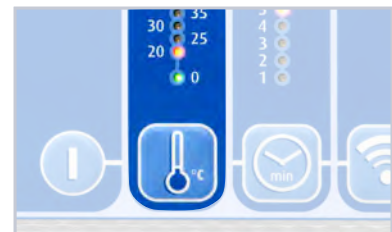

Dry-running protection of heating

- Automatic switch-off in case of overtemperature, by a too low fill level, for example.

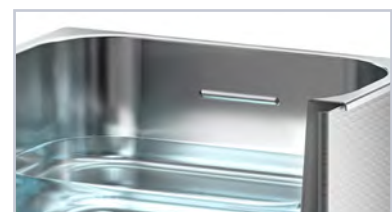

SONOREX – Control

Ultrasonic baths in three versions

SONOREX SUPER RK

Classic turning knob control

Sizes of baths:

0.9–90.0 l



Ultrasonic baths with turning knobs including user-friendly crossbar, where time and/or temperature can be selected.

Product features



Time setting: 1–15 min and continuous operation



Adjustable temperature range:
H-Version 30–80 °C, adjustable in 5 K steps, with control lamps
RK 31 H: 65 °C fix adjusted



Easy and intuitive operation



Ultrasound



Pulse function:
steady - increases the wave frequency and thus amplifies the ultrasound effect



Sweep – Automatic frequency control for a homogeneous ultrasound field



SONOREX SUPER RK 510 H

SONOREX DIGITEC DT

Foil front panel, with fast degassing

Sizes of baths:

0.9–90.0 l



Ultrasonic baths with digital controls where temperature and/or time can be set and fast degassing can be activated.

Four unit sizes are available with infrared interface: Type DT ... H-RC. Comfortable operation and process documentation.

Product features



Time setting: 1, 2, 3, 4, 5, 10, 15, 30 min and continuous operation, Display of preset time and remaining time by LED lamps



Adjustable temperature range: H-Version 20–80 °C, adjustable in 5 K steps, Display of set/actual temperature by LED lamps



Warning signal when the set temperature is exceeded, warning LED



Easy and intuitive operation



Foil front panel, especially hygienic



Automatic safety shutdown after 12 h



Data memory for 1 programm



DEGAS function, fast degassing



Ultrasound



Pulse function: steady - increases the wave frequency and thus amplifies the ultrasound effect



Sweep – Automatic frequency control for a homogeneous ultrasound field



SONOREX DIGITEC DT 510 H

SONOREX DIGIPLUS DL

Foil front panel, with fast degassing and power setting

Sizes of baths:

3.0–28.0 l



In addition to the parameters that can be selected on the SONOREX DIGITEC, the ultrasonic power can be adjusted in 10% steps. This is the case, for example, for gentle treatment of particularly sensitive surfaces, glass surfaces, coatings or unstructured silicon substrates (wafers).

Product features



Time setting: 1, 2, 3, 4, 5, 10, 15, 30 min and continuous operation, Display of preset time and remaining time by LED lamps



Adjustable temperature range: H-Version 20–80 °C, adjustable in 5 K steps, Display of set/actual temperature by LED lamps



Warning signal when the set temperature is exceeded, warning LED



Easy and intuitive operation



Foil front panel, especially hygienic



Automatic safety shutdown after 12 h



Data memory for 1 program



Power setting 20–100 % in 10 % steps, Display of the setting value by LED lamps



DEGAS function, fast degassing



Ultrasound



Pulse function: steady - increases the wave frequency and thus amplifies the ultrasound effect



Sweep – Automatic frequency control for a homogeneous ultrasound field



SONOREX DIGIPLUS DL 510 H

SONOREX

The variants – in comparison



	SUPER RK ...	DIGITEC DT ...	DIGIPLUS DL ...
Capacity [l]	0.9–90.0	0.9–90.0	3.0–28.0
Time setting [min]	1–15, ± 5 % continuous operation (∞)	1, 2, 3, 4, 5, 10, 15, 30, ± 5 % continuous operation (∞)	1, 2, 3, 4, 5, 10, 15, 30, ± 5 % continuous operation (∞)
Automatic safety shutdown	–	after 12 h	after 12 h
Heating	optional, H-version	optional, H-version	✓
Adjustable temperature range [°C]	30–80 RK 31 H: 65 fix	20–80	20–80
Excess temperature signal	–	✓	✓
Protection against boiling retardation	–	✓	✓
Setting accuracy of bath temperature	in 5 K steps	in 5 K steps	in 5 K steps
Thickness tank [mm], material C-version	0.8/1.4301 2.0/1.4404	0.8/1.4301 2.0/1.4404	0.8/1.4301 –
Filling mark for safe dosage	✓	✓	✓
Hard chromium-plated	RK 102 H	DT 102 H/H-RC	DL 102 H
One-piece drain, welded	✓, from RK 102 H	✓, from DT 102 H	✓
Degree of protection	IP 32	IP 33	IP 33
Ultrasonic frequency [kHz]	35	35	35
SweepTec	✓	✓	✓
Pulse function	✓	✓	✓
Power setting	–	–	20–100 % in 10 % steps
Oscillating systems	✓	✓	✓
Fast degassing DE GAS	–	✓	✓
Mains supply: 230 V~ (±10 %) 50/60 Hz 115 V~ (±10 %) 50/60 Hz	✓ optional	✓ optional	✓ optional
Data memory	–	1	1
Interface/PC Software	–	RS 232, USB at type H-RC: WINSONIC® Software/✓	–
Medical device class I	✓	✓	–

SONOREX SUPER

Ultrasonic baths with easy-to-operate turning knobs



Type	Internal tank dimensions l x w x d [mm]	Capacity [l]	Code No.	External dimensions l x w x h [mm]	Ultrasonic peak power* [W]	Ultrasonic nominal power [W]	Heating power [W]	Outlet ball valve
RK 31			329		160	40	–	–
RK 31 H	190 × 85 × 60	0.9	7523	205 × 100 × 180	160	40	70	–
RK 52			311		240	60	–	–
RK 52 H	150 × 140 × 100	1.8	164	175 × 165 × 225	240	60	140	–
RK 100			301		320	80	–	–
RK 100 H			312		320	80	140	–
RK 102 H	240 × 140 × 100	3.0	303	260 × 160 × 250	480	120	140	G ½
RK 103 H	240 × 140 × 150	4.0	326	260 × 160 × 310	560	140	200	G ½
RK 106	∅ 240 × 130	5.6	306	∅ 265 × 270	480	120	–	G ½
RK 156	500 × 140 × 100	6.0	305	530 × 165 × 245	640	160	–	G ½
RK 156 BH	500 × 140 × 150	9.0	646	530 × 165 × 300	860	215	600	G ½
RK 170 H	1000 × 200 × 200	39.0	7506	1050 × 250 × 385	1520	380	1600	G ½
RK 255			3066		640	160	–	G ½
RK 255 H	300 × 150 × 150	5.5	316	325 × 175 × 295	640	160	280	G ½
RK 510			327		640	160	–	G ½
RK 510 H	300 × 240 × 150	9.7	321	325 × 265 × 300	640	160	400	G ½
RK 512 H	300 × 240 × 200	13.0	795	325 × 265 × 350	860	215	400	G ½
RK 514			277		860	215	–	G ½
RK 514 H	325 × 300 × 150	13.5	207	355 × 325 × 305	860	215	600	G ½
RK 514 BH	325 × 300 × 200	18.7	263	355 × 325 × 385	860	215	600	G ½
RK 1028			322		1200	300	–	G ½
RK 1028 H	500 × 300 × 200	28.0	324	535 × 325 × 400	1200	300	1300	G ½
RK 1028 C	500 × 300 × 300	45.0	661	540 × 340 × 500	2000	500	–	G ½
RK 1028 CH	500 × 300 × 300	45.0	143	540 × 340 × 500	1200	300	1450	G ½
RK 1040	∅ 500 × 195	39.5	319	∅ 540 × 500	1520	380	–	G ½
RK 1050	600 × 500 × 200	58.0	323	640 × 540 × 425	2400	600	–	G ½
RK 1050 CH	600 × 500 × 300	90.0	184	640 × 540 × 530	2400	600	1950	G ½

*corresponds to 4 times ultrasonic nominal power

SONOREX DIGITEC

Ultrasonic baths with fast degassing



Type	Internal tank dimensions l x w x d [mm]	Capacity [l]	Code No.	External dimensions l x w x h [mm]	Ultrasonic peak power* [W]	Ultrasonic nominal power [W]	Heating power [W]	Outlet ball valve
DT 31	190 × 85 × 60	0.9	3200	205 × 100 × 180	160	40	–	–
DT 31 H			3220		160	40	70	–
DT 52	150 × 140 × 100	1.8	3205	175 × 165 × 230	240	60	–	–
DT 52 H			3225		240	60	140	–
DT 100	240 × 140 × 100	3.0	3210	260 × 160 × 250	320	80	–	–
DT 100 H			3230		320	80	140	–
DT 102 H			3235		480	120	140	G ¼
DT 103 H	240 × 140 × 150	4.0	3201	260 × 160 × 310	560	140	200	G ¼
DT 106	∅ 240 × 130	5.6	3270	∅ 265 × 270	480	120	–	G ¼
DT 156	500 × 140 × 100	6.0	3275	530 × 165 × 245	640	160	–	G ¼
DT 156 BH	500 × 140 × 150	9.0	3221	530 × 165 × 300	860	215	600	G ¼
DT 255	300 × 150 × 150	5.5	3215	325 × 175 × 295	640	160	–	G ¼
DT 255 H			3240		640	160	280	G ¼
DT 510	300 × 240 × 150	9.7	3245	325 × 265 × 300	640	160	–	G ½
DT 510 H			3206		640	160	400	G ½
DT 512 H	300 × 240 × 200	13.0	3226	325 × 265 × 350	860	215	400	G ½
DT 514	325 × 300 × 150	13.5	3250	355 × 325 × 305	860	215	–	G ½
DT 514 H			3211		860	215	600	G ½
DT 514 BH	325 × 300 × 200	18.7	3216	355 × 325 × 385	860	215	600	G ½
DT 1028	500 × 300 × 200	28.0	3255	535 × 325 × 400	1200	300	–	G ½
DT 1028 H			3231		1200	300	1300	G ½
DT 1028 CH	500 × 300 × 300	45.0	3266	540 × 340 × 500	1200	300	1450	G ½
DT 1050 CH	600 × 500 × 300	90.0	3271	640 × 540 × 530	2400	600	1950	G ½

*corresponds to 4 times ultrasonic nominal power

DT ... RC baths with infrared interface for process documentation**

Type	Internal tank dimensions l x w x d [mm]	Capacity [l]	Code No.	External dimensions l x w x h [mm]	Ultrasonic peak power* [W]	Ultrasonic nominal power [W]	Heating power [W]	Outlet ball valve
DT 102 H-RC	240 x 140 x 100	3.0	3071	260 x 160 x 250	480	120	140	G ¼
DT 255 H-RC	300 x 150 x 150	5.5	3081	325 x 175 x 295	640	160	280	G ¼
DT 510 H-RC	300 x 240 x 150	9.7	3091	325 x 265 x 300	640	160	400	G ½
DT 514 BH-RC	325 x 300 x 200	18.7	3095	355 x 325 x 385	860	215	600	G ½

*corresponds to 4 times ultrasonic nominal power ** WINSONIC DT remote control for MICROSOFT® WINDOWS® required



WINSONIC® DT remote control, consisting of:

Infrared adapter IR 1 and software CD

Code No. 3090

The programme is designed for the operating system MICROSOFT WINDOWS 10, in connection with infrared adapter IR 1 it enables convenient operation and monitoring of the DIGITEC DT ... RC ultrasonic baths with RS-232-data interface or USB connection.

Interface for automation of laboratories

The RS-232 data interface to the laboratory computer allows individual control and monitoring tasks and integration into an automated laboratory line.

SONOREX DIGIPLUS

Ultrasonic baths with fast degassing and power settings



Type	Internal tank dimensions l x w x d [mm]	Capacity [l]	Code No.	External dimensions l x w x h [mm]	Ultrasonic peak power* [W]	Ultrasonic nominal power [W]	Heating power [W]	Outlet ball valve
DL 102 H	240 x 140 x 100	3.0	7180	260 x 160 x 250	480	120	140	G ¼
DL 156 BH	500 x 140 x 150	9.0	7181	530 x 165 x 300	860	215	600	G ¼
DL 255 H	300 x 150 x 150	5.5	7182	325 x 175 x 295	640	160	280	G ¼
DL 510 H	300 x 240 x 150	9.7	7183	325 x 265 x 300	640	160	400	G ½
DL 512 H	300 x 240 x 200	13.0	7184	325 x 265 x 350	860	215	400	G ½
DL 514 BH	325 x 300 x 200	18.7	7185	355 x 325 x 385	860	215	600	G ½
DL 1028 H	500 x 300 x 200	28.0	7186	535 x 325 x 400	1200	300	1300	G ½

*corresponds to 4 times ultrasonic nominal power



SONOREX

Application-specific accessories

The important message is set at the beginning: Vessels or objects to be cleaned may not be placed on the tank bottom as this can damage the bottom of the tank, the vessels, or the objects to be cleaned. A distance of approx. 1–2 cm should be present below the object to be sonicated to allow for formation of the ultrasonic waves.

Furthermore, direct friction of the vessels/objects against the bottom of the tank would accelerate cavitation erosion and thus also wear.

Selecting the right accessories makes ultrasound use easier and protects the oscillating tank and laboratory equipment.

The following explains which accessories are logically used for which purpose.

Feel free to contact us at any time for advice on which accessories are recommended for your application or special use.



An overview of the accessories for the respective ultrasonic bath and their combination options can be found on pages 46–49.

Insert basket K

The insert basket is generally the first choice for placement of the goods to be treated.

There is a classic stainless steel basket for optimum ultrasound transmittance, as well as variants made of plastic for sensitive surfaces or especially small or large parts. Some of the basket brackets are fitted with heat-shrinkable sleeves. This protects against damage caused by friction at the tank edge and ensures noise



K 14

damping during operation. When selecting the device, the dimensions of the insert basket must be observed.

Insert basket PK 2 C

Use when cleaning parts with sensitive surfaces. Material: polyethylene, the bottom is perforated.



PK 2 C

The basket brackets are fitted with heat-shrinkable sleeves to protect the tank edge.

Utensil holder GH

The stainless steel utensil holder is especially designed to hold larger laboratory flasks or individual parts. Some of the basket brackets are fitted with heat-shrinkable sleeves (made of irradiation cross-linked polyolefin). This protects against damage to the tank edge and ensures noise damping during operation.

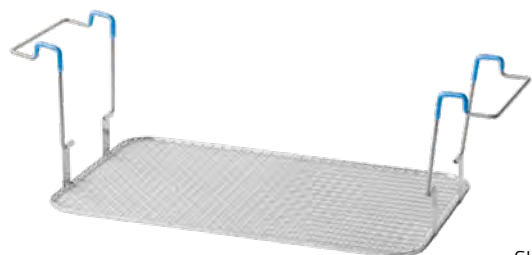

GH 28

Lid D

All D lids are made of stainless steel. Condensation water is discharged in the oscillating tank. The slots on the sides are used to feed the basket brackets through during operation. Compared to plastic lids, stainless steel lids do not become brittle or bend when exposed



D 514

to greater heat. The smooth surface is easy to clean. It serves as protection against external contamination.

Accessories for indirect sonication

Certain media, such as acids or solutions of halogenated salts (e.g. NaCl table salt, fluorides) cannot be used directly in the oscillating tank. These are "corrosives" whose effectiveness is further enhanced by ultrasound. This would result in increased pitting on the

tank bottom. When distilled/deionised water is used without additives, accelerated erosion occurs on the tank bottom – ions as cavitation germs are missing. Plastic tanks and inset beakers enable the indirect use of these media in the ultrasonic bath.

Insert tub KW

With lid.

KW 3/5 made of polyethylene, other KW made of polypropylene, temperature resistant in water up to 80 °C, in acids up to 60 °C. KW 14 lid made of polycarbonate.



KW 3

Positioning lid DE and beaker holder ES 4

The DE positioning lid and the ES 4 beaker holder, made of stainless steel, are used to hold inset beakers and enable optimal use of the ultrasound energy.



DE 100

ES 4

Inset beakers EB / KB / PD / SD

The inset beakers are used for indirect cleaning of small parts and fit into the DE positioning lids and the ES 4 beaker holders. The immersion depth can be varied using the rubber ring. The cleaning in cups facilitates a quick change of the cleaning liquid.

From unit size RK 100 can be cleaned simultaneously in two or more beakers filled with different cleaning solutions.



EB 05

PD 06

SD 06

Inset baskets KD 0 / PD 04

The inset basket is placed in the inset beaker and is thus optimally centred. Small parts to be cleaned can be easily placed in or removed from the inset beaker.

KD 0

Stainless steel, interior diameter 75 mm, sieve cloth, mesh size 1 × 1 mm



KD 0

PD 04

Polyethylene, interior diameter 60 mm, sieve cloth bottom, mesh size 1 × 1 mm



PD 04

SONOREX

Accessories for the process technology

HOLDERS for laboratory vessels

Samples should be homogenised, extracted or degassed quickly and reliably in an ultrasonic bath for subsequent analysis in laboratory vessels of various sizes and shapes. Securely fixing the laboratory flasks in the

insert basket is often a problem here. The laboratory flasks should not tip over, be flooded, or be moved by the ultrasound and collide with one another.

Spring clamp EK

Spring clamps are fastened in the insert basket or utensil holder, with a mesh size of up to 12.5 x 12.5 mm, and securely affix the laboratory flasks. This prevents the laboratory flasks from floating or tipping over.

They specify the size of the laboratory vessels to be affixed from 10–250 ml.

- EK 10 for 10-ml-flasks up to max. \varnothing 31 mm, min. \varnothing 23 mm
- EK 25 for 25-ml-flasks up to max. \varnothing 42 mm, mind. \varnothing 30 mm
- EK 50 for 50-ml-flasks up to max. \varnothing 52 mm, mind. \varnothing 35 mm
- EK 100 for 100-ml-flasks up to max. \varnothing 65 mm, mind. \varnothing 40 mm
- EK 250 for 250-ml-flasks up to max. \varnothing 85 mm, mind. \varnothing 55 mm



Spring clamp EK



ZF, mounted in the insert basket



Holder for laboratory flasks ZF

Tension springs ZF offer a simple solution. They can be quickly and easily attached using small hooks to any position on the edge of the insert basket, as lengthwise or crosswise dividers. The user can thus define the compartment size individually, depending on the flask shape and size. This guarantees that the flasks will be stable. The size of each division can be easily adjusted in seconds. A suitable coupling to the contact liquid, and thus an ultrasonic transmission without losses into the sample to be sonicated, are ensured.

Handle adjustment GV

In order to continue guaranteeing the two-thirds fill level in deeper ultrasonic baths and to avoid flooding of the laboratory flasks, an adjustment of the handle is recommended. This allows for an infinitely variable adjustment of the insertion depth of the insert basket with laboratory flasks included.

A suitable coupling to the contact liquid, and thus an ultrasonic transmission without losses into the sample to be sonicated, are ensured.



Handle adjustment GV

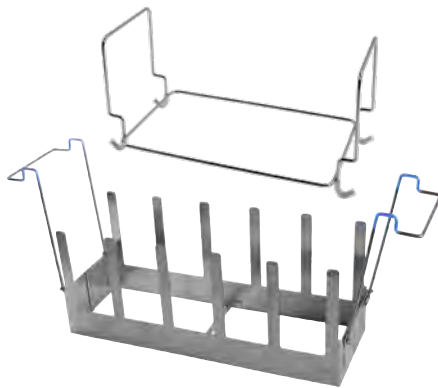

SH 7 and SH 28 C sieve holders

Sieve holder SH

The SH sieve holders are used to hold analysis sieves of up to a diameter of 215 mm.

SH 7: Accommodation of a sieve; for RK/DT 106

SH 28 C: Holds up to five sieves;
for RK 1028 C/CH/DT 1028 CH
The sieves are set vertically in the bath.

Test tube holder RG 2.2

The stainless steel test tube holder is intended for the simultaneous sonication of six test tubes/centrifuge tubes with $\varnothing = 30$ mm and six test tubes/centrifuge tubes with $\varnothing = 17$ mm.



Test tube holder RG 2.2

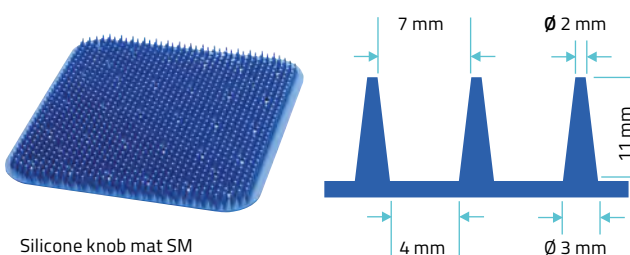

Silicone knob mat SM

Silicone knob mat SM

Easy to attach using the supplied plastic press studs on the bottom of the insert basket. Delicate objects to be cleaned can thus be safely placed and gently cleaned.

Configuration examples

One ultrasonic bath, direct and indirect sonication in one work step

In larger ultrasonic baths, direct sonication and indirect sonication can be performed simultaneously. This makes possible the use of different cleaning agents.

An insert basket K is used for cleaning of larger parts and a DE positioning lid with inset beakers is used for simultaneous cleaning of small parts.

Indirect sonication

of small parts in inset beakers, even when using solvents or acids

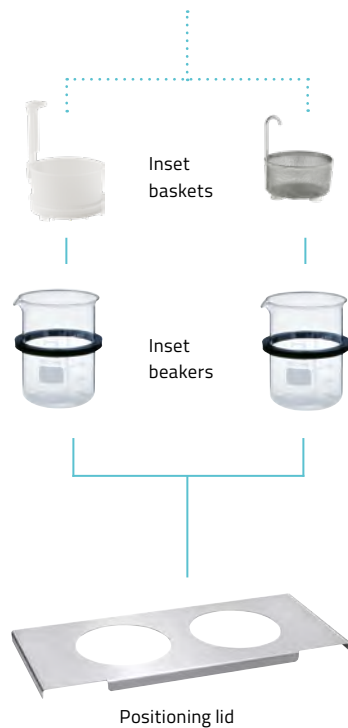

Direct sonication

of parts in the insert basket in the oscillating tank

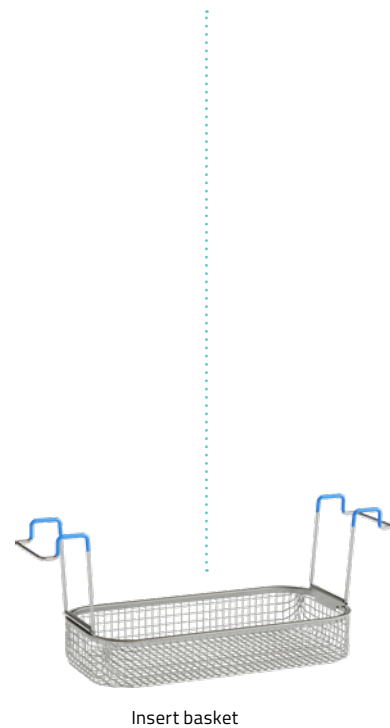

Ultrasonic bath

One ultrasonic bath, three configuration options

Different applications can be carried out in an ultrasonic bath by using different accessories.

Depending on the application, an insert basket, a plastic tray, or a positioning lid with inset beakers can be used.



SONOREX Accessories

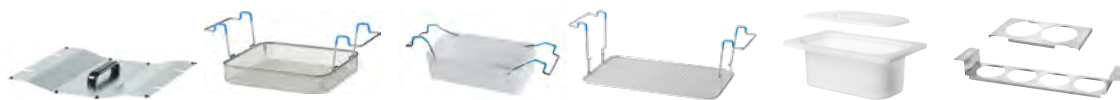

Ultrasonic bath	Lid (Code No.)	Insert basket stainless steel l x w x h [mm] (Code No.)	Insert basket plastic l x w x h [mm] (Code No.)	Utensil holder Bottom dimensions l x w [mm] (Code No.)	Insert tub (Code No.)	Positioning lid Beaker holder (Code No.)
RK 31/H DT 31/H	D 08 (218)	K 08 170 x 65 x 50 (209)	–	–	–	DE 08 2 holes (278)
RK 52/H DT 52/H	D 52 (3002)	K 1 C 120 x 110 x 40 (3024)	–	GH 1 129 x 117 (129)	–	DE 52 1 hole (3016)
RK 100/H DT 100/H	D 100 (3003)	K 3 C 200 x 110 x 40 (3025)	PK 2 C 187 x 90 x 56 (3082)	GH 1 129 x 117 (129)	KW 3 195 x 115 x 88 (715)	DE 100 2 holes (3017)
RK 102 H DT 102 H /H-RC DL 102 H	D 100 (3003)	K 3 C 200 x 110 x 40 (3025)	PK 2 C 187 x 90 x 56 (3082)	GH 1 129 x 117 (129)	KW 3 195 x 115 x 88 (715)	DE 100 2 holes (3017)
RK 103 H DT 103 H	D 100 (3003)	K 3 CL 200 x 110 x 40 (3026)	–	GH 1 129 x 117 (129)	KW 3 195 x 115 x 88 (715)	DE 100 2 holes (3017)
RK 106 DT 106	D 6 (346)	K 6 Ø 215 x 50 (356)	–	–	–	DE 6 2 holes (336)
RK 156 DT 156	D 156 (3004)	K 6 L 460 x 100 x 50 (202)	–	3 x GH 1 129 x 117 (129)	–	DE 156 4 holes (3040)
RK 156 BH DT 156 BH DL 156 BH	D 156 (3004)	K 6 BL 460 x 100 x 50 (629)	–	–	–	DE 156 4holes (3040)
RK 170 H	D 170 (3006)	K 7 950 x 150 x 50 (577)	–	–	–	–
RK/DT 255/H DT 255 H-RC DL 255 H	D 255 (3007)	K 5 C 260 x 110 x 40 (3027)	–	–	KW 5 254 x 96 x 130 (240)	DE 255 2 holes (3028)
RK/DT 510/H DT 510 H-RC DL 510 H	D 510 (3008)	K 10 250 x 195 x 50 (359) or 1 x K 5 C 260 x 110 x 40 (3027) or 2 x K 3 CL 200 x 110 x 40 (3026)	–	GH 10 260 x 200 (292)	KW 10-0 242 x 182 x 136 (3053) or 1x KW 5 254 x 96 x 130 (240) or 1x KW 3 195 x 115 x 88 (715)	DE 510 4 holes (3038) or 1 x DE 100 2 holes (3017) or 1 x DE 255 2 holes (3028)

In this overview you will find the matching accessories for our units (continued on the next pages).



	Inset beaker	Inset basket	Handle adjustment	Spring clamps	Holder for laboratory flasks	Sieve holder	Test tube holder
	(Code No.)	(Code No.)	(Code No.)	(Code No.)	(Code No.)	(Code No.)	(Code No.)
	SD 04 (168) SD 05 (575) KB 04 (3000)	PD 04 (126)	–	1 × EK 10 (7521) or 1 × EK 25 (7519) or 1 × EK 50 (7518) or 1 × EK 100 (7516)	–	–	–
	EB 05 (340) SD 06 (330) PD 06 (299) SD 09 (579)	KD 0 (370) PD 04 (126)	GV 3 (7509) nicht passend zu GH 1	1 × EK 10 (7521) or 1 × EK 25 (7519) or 1 × EK 50 (7518) or 1 × EK 100 (7516) or 1 × EK 250 (3259)	–	–	RG 2.2 (279)
	EB 05 (340) SD 06 (330) PD 06 (299) SD 09 (579)	KD 0 (370) PD 04 (126)	GV 3 (7509) nicht passend zu GH 1	8 × EK 10 (7521) or 5 × EK 25 (7519) or 4 × EK 50 (7518) or 2 × EK 100 (7516) or 2 × EK 250 (3259)	–	–	RG 2.2 (279)
	EB 05 (340) SD 06 (330) PD 06 (299) SD 09 (579)	KD 0 (370) PD 04 (126)	GV 3 (7509) nicht passend zu GH 1	8 × EK 10 (7521) or 5 × EK 25 (7519) or 4 × EK 50 (7518) or 2 × EK 100 (7516) or 2 × EK 250 (3259)	–	–	RG 2.2 (279)
	EB 05 (340) SD 06 (330) PD 06 (299) SD 09 (579)	KD 0 (370) PD 04 (126)	GV 3 (7509) nicht passend zu GH 1	8 × EK 10 (7521) or 5 × EK 25 (7519) or 4 × EK 50 (7518) or 2 × EK 100 (7516) or 2 × EK 250 (3259)	–	–	RG 2.2 (279)
	EB 05 (340) SD 06 (330) PD 06 (299) SD 09 (579)	KD 0 (370) PD 04 (126)	–	–	–	SH 7 (314)	–
	EB 05 (340) SD 06 (330) PD 06 (299) SD 09 (579)	KD 0 (370) PD 04 (126)	–	–	–	–	–
	EB 05 (340) SD 06 (330) PD 06 (299) SD 09 (579)	KD 0 (370) PD 04 (126)	GV 3 (7509)	–	–	–	–
	–	–	–	–	–	–	–
	EB 05 (340) SD 06 (330) PD 06 (299) SD 09 (579)	KD 0 (370) PD 04 (126)	–	10 × EK 10 (7521) or 7 × EK 25 (7519) or 5 × EK 50 (7518) or 3 × EK 100 (7516) or 3 × EK 250 (3259)	–	–	–
	EB 05 (340) SD 06 (330) PD 06 (299) SD 09 (579)	KD 0 (370) PD 04 (126)	GV 10 (7512)	15 × EK 10 (7521) or 11 × EK 25 (7519) or 8 × EK 50 (7518) or 5 × EK 100 (7516) or 6 × EK 250 (3259)	ZF 10 (3524)	–	–

SONOREX Zubehör

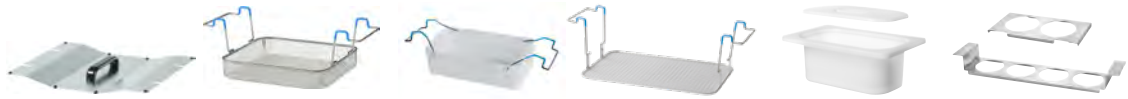

Ultrasonic bath	Lid (Code No.)	Insert basket stainless steel l x w x h [mm] (Code No.)	Insert basket plastic l x w x h [mm] (Code No.)	Utensil holder Bottom dimensions l x w [mm] (Code No.)	Insert tub (Code No.)	Positioning lid Beaker holder (Code No.)
DT 510 F	D 510 (3008)	K 10 F 250 x 195 x 35 (35902)	–	–	–	–
RK 512 H DT 512 H DL 512 H	D 510 (3008)	K 10 B 250 x 195 x 50 (230)	–	–	–	DE 510 4 holes (3038)
RK 514/H DT 514/H	D 514 (3010)	K 14 275 x 245 x 50 (354) or 2 x K 5 C 260 x 110 x 40 (3027)	–	GH 14 280 x 250 (291)	KW 14 280 x 215 x 145 (613) or 1 x KW 5 254 x 96 x 130 (240)	DE 514 4 holes (3039) or 1 x DE 255 2 holes (3028)
RK/DT 514 BH DT 514 BH-RC DL 514 BH	D 514 (3010)	K 14 B 275 x 245 x 50 (205)	–	–	KW 14 B 275 x 210 x 195 (648)	DE 514 4 holes (3039)
RK 1028/H DT 1028/H DL 1028 H	D 1028 (3011)	K 28 455 x 245 x 50 (358) or x 2 K 10 B 250 x 195 x 50 (230)	–	GH 28 455 x 250 (290)	KW 28-0 437 x 230 x 155 (717) or 2x KW 10-0 242 x 182 x 136 (3053)	2 x ES 4 4 holes (382)
RK 1028 C RK 1028 CH DT 1028 CH	D 1028 C (3012)	K 28 C 455 x 245 x 50 (181)	–	–	KW 28-0 437 x 230 x 155 (717)	2 x ES 4 4 holes (382)
DT 1028 F	–	2 x K 10 F 250 x 195 x 35 (35902)	–	–	–	–
RK 1040	D 40 (603)	K 40 Ø 480 x 50 (123)	–	GH 28 455 x 250 (290)	–	–
RK 1050	D 1050 C (3013)	K 50 545 x 450 x 50 (357) or 2 x K 28 455 x 245 x 50 (189)	–	–	KW 50 B-0 520 x 445 x 284 (568)	4 x ES 4 4 holes (382)
RK 1050 CH DT 1050 CH	D 1050 C (3013)	K 50 C 545 x 450 x 50 (138) or 2 x K 28 C 455 x 245 x 50 (194)	–	–	KW 50 B-0 520 x 445 x 284 (568) or x 1 KW 28-0 437 x 230 x 155 (717)	4 x ES 4 4 holes (382)

In this overview you will find the matching accessories for our units (continued from the previous pages).



	Inset beaker	Inset basket	Handle adjustment	Spring clamps	Holder for laboratory flasks	Sieve holder	Test tube holder
	(Code No.)	(Code No.)	(Code No.)	(Code No.)	(Code No.)	(Code No.)	(Code No.)
	–	–	–	15 × EK 10 (7521) or 11 × EK 25 (7519) or 8 × EK 50 (7518) or 5 × EK 100 (7516) or 6 × EK 250 (3259)	ZF 10 (3524)	–	–
	EB 05 (340) SD 06 (330) PD 06 (299) SD 09 (579)	KD 0 (370) PD 04 (126)	GV 10 (7512)	15 × EK 10 (7521) or 11 × EK 25 (7519) or 8 × EK 50 (7518) or 5 × EK 100 (7516) or 6 × EK 250 (3259)	ZF 10 (3524)	–	–
	EB 05 (340) SD 06 (330) PD 06 (299) SD 09 (579)	KD 0 (370) PD 04 (126)	GV 10 (7512)	20 × EK 10 (7521) or 15 × EK 25 (7519) or 10 × EK 50 (7518) or 8 × EK 100 (7516) or 8 × EK 250 (3259)	–	–	–
	EB 05 (340) SD 06 (330) PD 06 (299) SD 09 (579)	KD 0 (370) PD 04 (126)	GV 10 (7512)	20 × EK 10 (7521) or 15 × EK 25 (7519) or 10 × EK 50 (7518) or 8 × EK 100 (7516) or 8 × EK 250 (3259)	–	–	–
	EB 05 (340) SD 06 (330) PD 06 (299) SD 09 (579)	KD 0 (370) PD 04 (126)	GV 10 (7512)	32 × EK 10 (7521) or 28 × EK 25 (7519) or 18 × EK 50 (7518) or 13 × EK 100 (7516) or 14 × EK 250 (3259)	ZF 28 (3525)	–	–
	EB 05 (340) SD 06 (330) PD 06 (299) SD 09 (579)	KD 0 (370) PD 04 (126)	GV 10 (7512)	32 × EK 10 (7521) or 28 × EK 25 (7519) or 18 × EK 50 (7518) or 13 × EK 100 (7516) or 14 × EK 250 (3259)	ZF 28 (3525)	SH 28 (307)	–
	–	–	–	32 × EK 10 (7521) or 28 × EK 25 (7519) or 18 × EK 50 (7518) or 13 × EK 100 (7516) or 14 × EK 250 (3259)	2 × ZF 10 (3524)	–	–
	–	–	–	–	–	–	–
	EB 05 (340) SD 06 (330) PD 06 (299) SD 09 (579)	KD 0 (370) PD 04 (126)	–	–	–	–	–
	EB 05 (340) SD 06 (330) PD 06 (299) SD 09 (579)	KD 0 (370) PD 04 (126)	–	–	–	–	–

Ultrasonic baths for special requirements



**SONOREX PR 140 DH –
Ultrasonic bath for cleaning
of volumetric glassware**

For clean and above all greaseless
glass volume measuring devices up
to 755 mm in length

[from page 60](#)

04



**SONOREX DIGITEC DT ... F –
Ultrasonic baths with
flat oscillating tanks**

Especially practical for homogenisation, sample preparation and rapid degassing of samples.

from page 52



**SONOSHAKE – Ultrasonic bath
with shaking device
for sample preparation**

Ideally equipped for the field of analytics and medical diagnostics.

from page 54



**Recirculating chiller
LABOCOOL LC 400**

Every ultrasonic bath can now be expanded with a cooling function.

from page 56



**SONOREX Ultrasonic baths
for cleaning of analysis sieves**

Removes impurities from even the finest mesh and ensures reliably reproducible results.

from page 62



**SONOCOOL –
Ultrasonic bath with cooling**

For a constant temperature with heat-sensitive samples in analytical laboratories and pathologies.

from page 64



**BactoSonic –
Ultrasonic bath
for gentle removing of biofilms**

Reliably frees medical implants from infectious microorganisms.

from page 68

SONOREX DIGITEC DT...F

Ultrasonic baths with flat oscillating tanks

Flat baths are especially designed for homogenisation or sample preparation and rapid degassing of samples in laboratory vessels. Uniform sonication of all samples, regardless of their size and arrangement, is conducted at a higher power intensity [W/l] than in the standard ultrasonic bath. This guarantees reproducible results. Due to the shallower tank depth, the need for contact liquid is also lower. Spring clamps for the vessels prevent them from tipping over or floating.

Advantages

- Uniform sonication of samples irrespective of size and arrangement of the flasks
- Reproducible results
- Homogenising or fast degassing of samples
- Holder for laboratory flasks ZF and spring clamps EK prevent floating or tilting of laboratory flasks



Type	Internal tank dimensions l x w x d [mm]	Capacity [l]	Code No.	External dimensions l x w x h [mm]	Ultrasonic peak power* [W]	Ultrasonic nominal output [W]	Outlet ball Valve
DT 510 F	300 x 240 x 65	4.3	3242	325 x 265 x 195	560	140	G ½
DT 1028 F	500 x 300 x 65	9.5	3243	535 x 325 x 205	1280	320	G ½

*corresponds to 4 times nominal power



SONOREX DT 510 F (left) with holder for laboratory flasks and DT 1028 F (right) with spring clamps

Sets consisting of:

SONOREX DIGITEC DT 510 F, 1 basket K 10 F,
1 bottle TICKOPUR R 33
Code No. 13242

SONOREX DIGITEC DT 1028 F, 2 baskets K 10 F,
1 bottle TICKOPUR R 33
Code No. 13243



Spring clamps EK for laboratory flasks

Stainless steel spring clamps prevent the laboratory flasks from floating or tipping over.

Type	Code No.	for volume [ml]	Min. flask diameter [mm]	Max. flask diameter [mm]	Max. quantity of flasks for K 10 F [pcs.]
EK 10	7521	10	23	31	18
EK 25	7519	25	30	42	18
EK 50	7518	50	35	52	9
EK 100	7516	100	40	65	6
EK 250	3259	250	55	85	5



Holder for laboratory flasks ZF

Holder for laboratory flasks prevent the laboratory flasks from floating or tilting in the basket K 10 F.

Type	Code No.	Quantity [pcs.]
ZF 10	3524	5 x 155 mm 3 x 215 mm



SONOSHAKE Set

Ultrasonic bath with shaking device for sample preparation

With separate chiller LABOCOOL LC 400 expandable. (see p. 56-57)

The SONOSHAKE offers a wide range of applications for sample preparation in many areas of analysis, such as in environmental and food analytics as well as in medical diagnostics. The samples can be sonicated both for a defined period of time and also in continuous operation. Rapid degassing via the DEGAS function is also possible. The shaking device allows gentle to strong horizontal movement up to a maximum of 20 mm thanks to four different shaking frequencies. Both processes can be carried out simultaneously and also separately. For example, pre-homogenisation and final homogenisation with ultrasound are achieved with a defined shaking frequency, in a significantly shorter time. Any sediment in the sample can be loosened with defined shaking. Homogenisation is carried out by the additional ultrasound.

- Analogue settings of time and shaking frequency
- Reciprocating motion: settings in 4 steps possible
- Constant amplitude of 20 mm independently of loading
- Rack easy to remove
- Fast mounting of laboratory clamps EK 10 –250 (separately to order)
- Shaking platform approx. 410 × 280 mm [l × w]
- Required floor space approx. 850 × 360 mm [l × w]

The ultrasonic bath SONOREX DIGITEC DT 1028 F can easily be retrofitted with the SA 1028 shaking device. To cool temperature-sensitive samples during sonication and to remove process heat, the LC 400 recirculating chiller can be connected to the SA 1028 shaking device using the optionally available ELC 2 add-on module.



SONOSHAKE – Combination of flat ultrasonic bath and shaking device.

SONOSHAKE Set

Code No. 3257

consisting of:

ultrasonic bath DT 1028 F and shaking device SA 1028

Shaking device SA 1028

Code No. 3249



Spring clamps EK for laboratory flasks

Stainless steel spring clamps prevent the laboratory flasks from floating or tipping over.

Type	Code No.	for volume [ml]	Min. flask diameter [mm]	Max. flask diameter [mm]	Max. quantity of flasks [pcs.]
EK 10	7521	10	23	31	36
EK 25	7519	25	30	42	36
EK 50	7518	50	35	52	18
EK 100	7516	100	40	65	12
EK 250	3259	250	55	85	10



LABOCOOL LC 400 Recirculating chiller

LABOCOOL LC 400 is used for either removal of process heat or effective cooling of samples during sonication in an ultrasonic bath. Compared to conventional recirculating coolers, LABOCOOL LC 400 is characterised by a closed water circuit without equalisation tank, thus, the ultrasonic bath from overflowing.

Thanks to the natural refrigerant R-290, LABOCOOL LC 400 is particularly efficient and climate-friendly.

For applications with SONOPULS homogeniser: LABOCOOL LC 200

Applications with cooling

Sonication reduces the processing time for sample preparation for following analysis and enables more reproducible results. Due to the high ultrasonic power, frictional heat is generated which warms-up the sonication liquid in a short time.

In order to protect the sample from excessive heat input, many applications require the connection of an external cooling system. For this application, LABOCOOL LC 400 provides a ready-to-connect complete solution that always enables a cooling of samples at the push of a button.

For all SONOREX bath sizes up to 30 l volume and for SONOSHAKE

LABOCOOL LC 400 recirculating chiller for cooling is suitable for all SONOREX ultrasonic baths with bottom drain. The connection is made using the supplied hoses. Add-on module ELC 1 enables the connection of two ultrasonic baths at the same time.

To connect the SONOSHAKE, the ELC 2 add-on module is required. Thanks to the 3-way ball valve supplied, the tank emptying function is preserved.



Code No. 3851 for ELC 1



Code No. 3852 for ELC 2

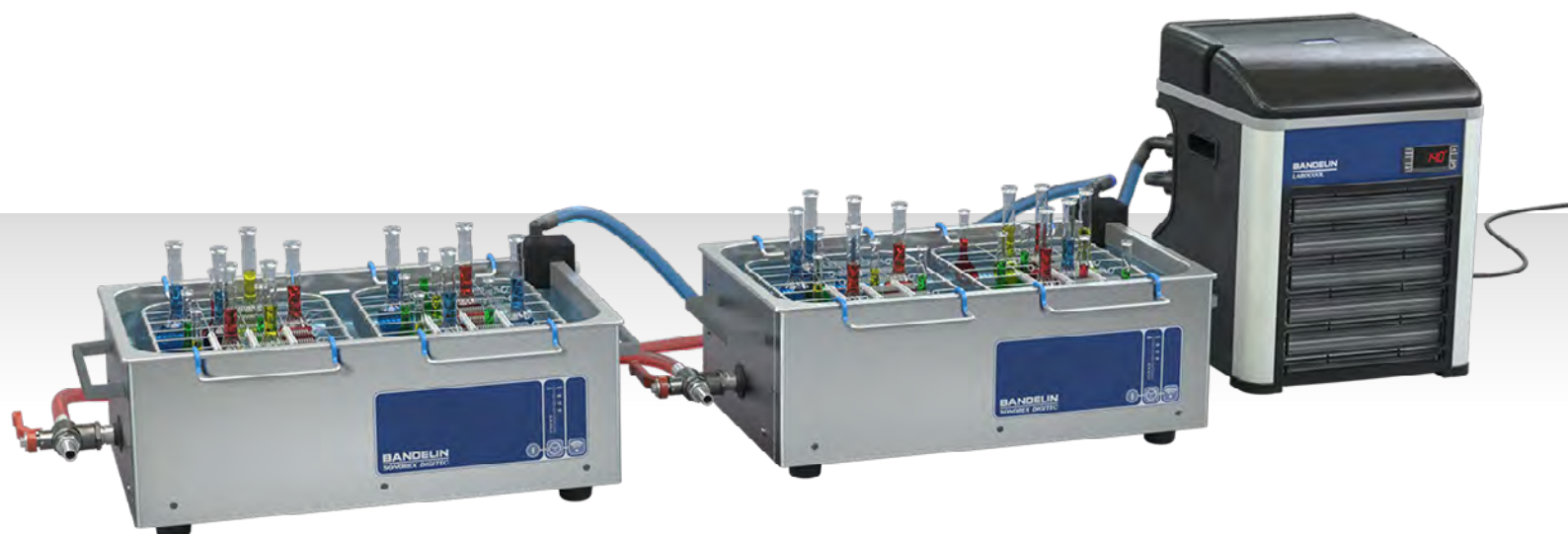

Connecting hub

This fits to all SONOREX ultrasonic baths up to 30 l and will be attached to the ultrasonic bath without tools. The use of baskets is not affected by the connecting hub.



Front side

The display shows the status of the cooling function and the water temperature in the ultrasonic bath. Via side buttons the desired water temperature can be selected within a range of 5–30 °C.



Operating panel

Supply air grille with rinsable air filter



Rear side

Pump unit and main switch are located at the rear of the device.

Vent hood with variable orientation

Exhaust air outlet

Hose connections with a 16 mm exterior diameter for hose supplied



Pump unit

Main switch

Power supply



Type	Code No.	For baths	External dimensions l x w x h [mm]	Cooling power [W]	Refrigerant type	Refrigerant quantity [g]	Pump type	Pump power [W]	Flow-through rate [l/h]
LC 400	3850	SONOREX	410 x 320 x 420	440	R-290	90	Centrifugal pump	10	600



BANDELIN
SONOREX DIGITEC

BANDELIN
LABORCOOL

14.0



SONOREX PR 140 DH

Ultrasonic bath for the cleaning of volumetric glassware with lengths up to 755 mm

Clean and particularly fatty-free glass surfaces are necessary for a correct volume measurement: The liquid to be measured must flow well down the glass wall and must not form droplets.

Features

- For reusable volumetric glassware as well as long parts up to 755 mm length
- Heating for better removing of fatty residues
- Frequency modulation "Sweep" for a very homogeneous ultrasonic field; damages at the glass surface are nearly prevented, attacking of graduation as well as glass corrosion will be avoided compared to manual cleaning with rough sponges or brushes
- Placing onto the floor near the drain is possible
- Simultaneous cleaning and disinfection with STAMMOPUR 24 in case of infectious contamination
- Biologically degradable agent TICKOPUR for gentle removing of stubborn fatty residues (R 33) or mineral ones (TR 3)
- Multiple use of cleaning solution is possible
- Ultrasonic tank made of stainless steel AISI 304 (1.5 mm thickness)
- Handles for easy transport within the lab
- Operation foil keypad guarantees a simple cleaning of the housing surface
- All functions like time, DEGAS or optionally temperature can be set at the push of the button
- Drain with ball valve for easy and fast emptying

Ready-to-operate set:

- Ultrasonic bath pipettes washer PR 140 DH
- Inset basket K 140 B
- Lid D 140 D
- Cleaning concentrates
TICKOPUR R 33 – 5 liters
TICKOPUR TR 3 – 1 liter



PR 140 DH with K 140 B and D 140 D

Type	Internal tank dimensions l x w x d [mm]	Capacity [l]	Code No.	External dimensions l x w x h [mm]	Ultrasonic peak power* [W]	Ultrasonic nominal power [W]	Heating power [W]	Outlet ball valve
PR 140 DH	150 x 150 x 895	min. 9 max. 18	2070	330 x 330 x 1003	860	215	700	G ½

*corresponds to 4 times nominal power



BANDELIN
SONOREX DIGITEC



SONOREX

Ultrasonic baths for the cleaning of analysis sieves

Analysis sieves are test equipment with very high accuracy which are especially used in the fields of quality control in research and production. A thorough cleaning of analysis sieves is the basis for precise and reproducible results. Therefore, manufacturer of sieves recommend a cleaning of sieves by ultrasound. By cleaning in an ultrasonic bath, the particles are removed also from finest meshes (< 500 µm), contamination of the next sample will be prevented. There is no changing of mesh size and material tension.

Not only analysis sieves can be cleaned effectively and thoroughly, but also a mill tools.

Analysed sieves which are used in sieve shakers are cleaned intensively and gentle within a few minutes. The sieves are ready for the next analysis within a very short time.

We recommend our universal cleaning concentrate TICKOPUR R 33 as well as a suitable sieve holder SH.



Analysis sieve before and after cleaning

For cleaning of a single sieve:

Type	Internal tank dimensions [mm]	Capacity [l]	Code No.	For analysis sieves up to Ø [mm]	Ultrasonic peak power* [W]	Ultrasonic nominal power [W]	Accessories [mm]	Code No.
DT 106	Ø 240, 130	5.6	3270	200	480	120	SH 7	314
RK 106	Ø 240, 130	5.6	326	200	480	120	SH 7	314
RK 1040	Ø 500, 195	39.5	319	500	1520	380	GH 28	290

*corresponds to 4-times nominal power



SONOREX SUPER RK 106 and SONOREX DIGITEC DT 106 with SH 7

SONOREX SUPER RK 1040 with GH 28

Cleaning of a single sieve with ultrasound in the SONOREX ultrasonic bath DT 106
youtube.com/bandelin

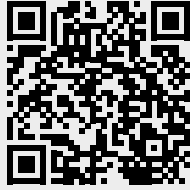

Cleaning of up to five sieves with ultrasound in the SONOREX ultrasonic bath RK 1028 CH
youtube.com/bandelin



DT 106 with SH 7



RK 1028 C with SH 28 C

For simultaneous cleaning of up to five sieves:

Type	Internal tank dimensions [mm]	Capacity [l]	Code No.	For analysis sieves up to Ø [mm]	Ultrasonic peak power* [W]	Ultrasonic nominal power [W]	Accessories [mm]	Code No.
RK 1028 C	500 × 300 × 300	45.0	661	200	2000	500	SH 28 C	307

*corresponds to 4-times nominal power

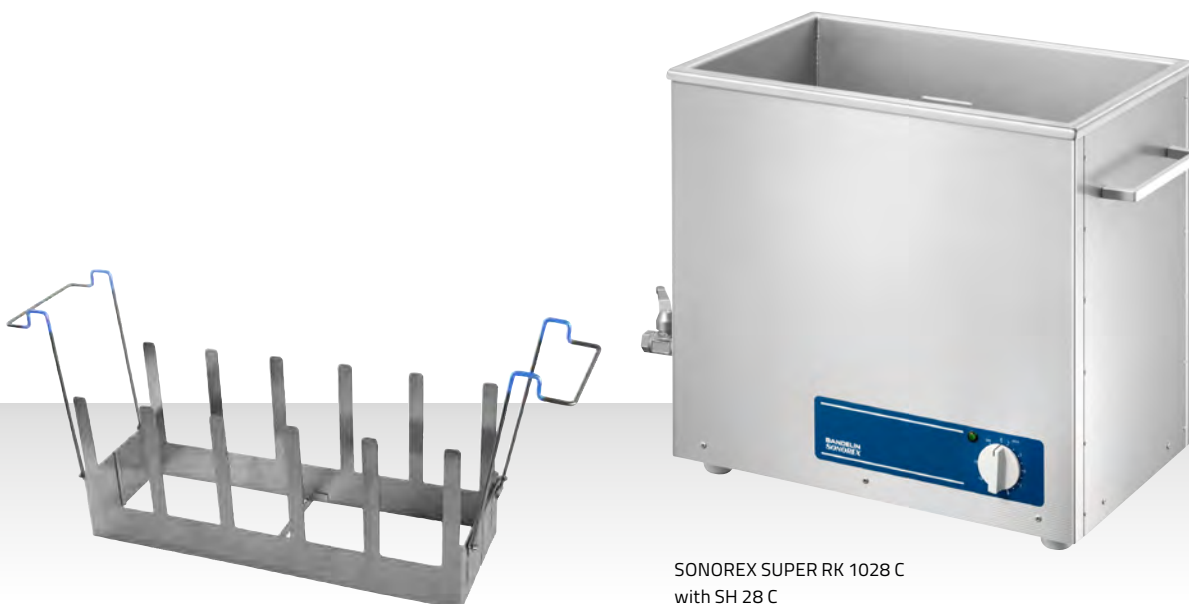

SONOREX SUPER RK 1028 C with SH 28 C

SONOCOOL

Ultrasonic bath with cooling for use in analytical laboratories and pathologies

The SONOCOOL ultrasound device is the best option for all instances in which temperature constancy in the ultrasonic bath is required, e.g. for quality control in the pharmaceutical industry, in the food and beverages industry, and also in pathology. Its scope of functions focuses on the essentials: Ultrasound intensity – Sonication time – Temperature.

Extensive accessories expand the possibilities for use. With the bath it is possible to use the catalytic effect of ultrasound for processes during which simultaneous cooling is required. Heat-sensitive samples are protected by the cooling function and process sequences can be designed to be faster and more effective than customary procedures.



Control panel of SONOCOOL ultrasonic bath



Welded tank (stainless steel AISI 316 L)

Advantages of the SONOCOOL SC 255.2

- Compact and powerful – ultrasound and cooling in one device
- Air-cooled cooling unit
- Climate-friendly refrigerant R-290
- Dissipation of the process heat caused by the ultrasound
- Adjustable bath temperature:
4 to 40 °C at 20 °C room temperature
- Individual parameter variation (time, temperature, performance) and thus adaptation to the respective test specimen
- Long lifespan – welded tank AISI 316 L, material thickness 2 mm
- Monitoring of the fill level
- Glass lid: Sample observation, easy cleaning



Stopcock and drain nozzle



Glass lid, integrated bracket

Examples for applications in laboratory

(constant temperature conditions required)

- Sample preparation for subsequent analysis, e.g. determination of chemical and biological agents (especially chromium [VI] analytics)
- Dissolve solids in solvents and degas eluents

Advantage: Temperature-sensitive materials are not destroyed/attacked.



Ready-to-use laboratory set:

- Ultrasonic bath SC 255.2
- Insert basket K 5 SC
- Lid D 255 G
- 1 bottle TICKOPUR TR 3 (concentrate for producing contact liquid)

Code No. 3500032 – 230 V EU plug CEE 7/7
 3500032-GB – 230 V GB-plug BS 1363
 3500032-CH – 230 V CH-plug T 12 Typ J

Examples for applications in pathology

- Acceleration of decalcification of femoral head preparations, shin stem preparations and osteosarcomas
- Acceleration of decalcification of hard tooth tissue for histopathological processing

Advantages: Significant reduction of decalcification times without negatively affecting the quality of the specimen and improvement of the cutting quality.



Ready-to-use pathology set:

- Ultrasonic bath SC 255.2
- Sample holder PH 255-11
- Lid D 255 G
- Insert beaker SD 01.2 – 20 pcs.
- 1 bottle TICKOPUR TR 3 (concentrate for producing contact liquid)

Code No. 3500031 – 230 V-EU plug CEE 7/7
 3500031-GB – 230 V-GB plug BS 1363
 3500031-CH – 230 V-CH plug T 12 Typ J

Type	Internal tank dimensions l × w × d [mm]	Capacity [l]	External dimensions l × w × h [mm]	Ultrasonic peak power* [W]	Ultrasonic nominal power [W]	Heating power [W]	Outlet
SONOCOOL	280 × 150 × 150	6.3	60 × 605 × 385	720	180	700	hose, front left, concealed

*corresponds to 4-times nominal power

Accessories available for the laboratory

BANDELIN offers the right accessories for various applications in the laboratory.

Insert basket K 5 SC
stainless steel
260 × 110 × 40 mm, l × w × d
Mesh size 5 × 5 mm
Load capacity max. 5 kg
Code No. 302701

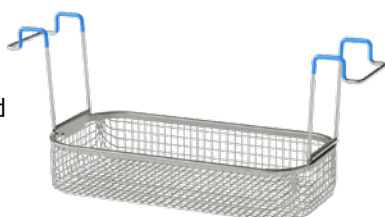

Stainless steel spring
clamps prevent the labo-
ratory flasks from floating
or tipping over.



Type	Code No.	For flasks [ml]	Min. flask diameter [mm]	Max. flask diameter [mm]	Max. quantity of flasks [pcs.]
EK 10	7521	10	23	31	17
EK 25	7519	25	30	42	10
EK 50	7518	50	35	52	7
EK 100	7516	100	40	65	4
EK 250	3259	250	55	85	2

Available accessories for the pathology

For various applications in pathology BANDELIN offers the right accessories.



Sample holder PH 255-1
for 1 box IB 18
Code No. 3519

Box IB 18
material: polypropylene
VPE = 5 pcs.
Code No. 3283



Sample holder PH 255-11
for 11 inset beakers SD 01.2
Code No. 3512

Inset beaker SD 01.2
VPE = 10 pcs. à 100 ml
material: glass, without spout
inner Ø 44 mm, height 80 mm
Code No. 3517

Sample holder PH 255-2
for 2 inset beakers SD 06
Code No. 3518



Inset beaker SD 06
material: glass, 600 ml
Innen Ø 84 mm, height 125 mm
with lid
Inserting without the black ring
Code No. 330



Sample holder PH-2W
for 2 x 24-well-plates
Code No. 3521

Detailed application examples in pathology for the SONOCOOL

Type	No.	Use
Decalcification	PT-101	Examination of the decalcification process at a variable ultrasonic output in a subjective comparison (Test cuttability, microscopic assessment)
Decalcification	PT-102	Checking the decalcification process with different ultrasound power and different decalcifying solution in objective comparison (contact radiography)
Decalcification	PT-103	Results of the decalcification for osteosarcomas
Decalcification	PT-104	Result of the biomolecular reprocessing of a bone preparation
Decalcification	PT-105	Acceleration of the decalcification process of hard tooth tissue in the SONOCOOL ultrasonic bath



BactoSonic

Ultrasonic bath for gentle removing of biofilms

With the increasing use of medical implants, we are also increasingly confronted with infectious biofilms on such implants. The most common implants include joint prostheses, osteosyntheses, vascular prostheses, pace-makers and defibrillators, dental implants, neurosurgical shunts and breast implants.

The success of therapy for implant infections depends on a precise microbiological diagnosis. Because microorganisms form biofilms on foreign bodies, they are often difficult to detect in surrounding tissues.

Sonication (ultrasound) can gently remove microorganisms from the surface of an infected implant. The implant is immersed in liquid so that the ultrasonic waves can act on the entire surface of the implant. After sonication, the liquid (the sonicate) is prepared for cultures and can then be used immediately in the subsequent analysis (e.g. PCR). Thus, sonication makes it possible to quickly diagnose the location of the infection when implants need to be removed.

The BactoSonic was developed in cooperation with a research institute.

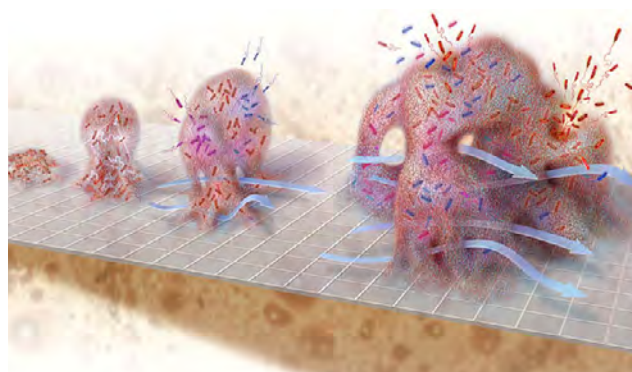

Planktonic and biofilm forms of bacteria

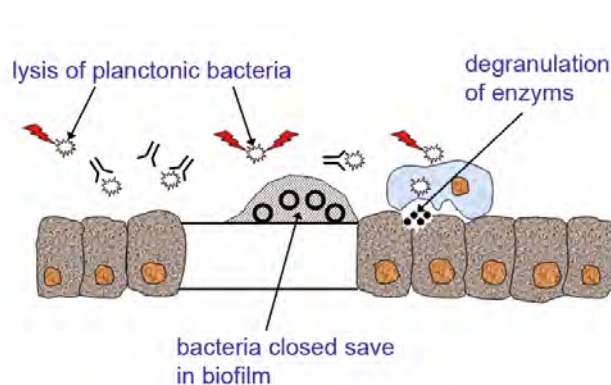

Biofilm on the implant surface

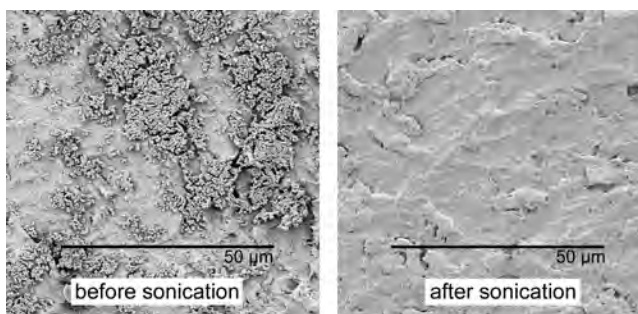

Success of biofilm removal



Comparison of cultures from tissue biopsy and sonication fluid (sonicate)

Principle of BactoSonic

The implants are placed in the airtight implant boxes and sonicated in the specially designed ultrasonic bath BactoSonic.

Compared to other ultrasonic baths, BactoSonic works with a very **low ultrasonic intensity and increased homogeneity**. The biofilm is removed without killing the bacteria, a quantitative assessment is possible.

The sonicated liquid is cultured and the quantity of bacteria can be determined. Compared to standard methods (e.g. biopsies from periprosthetic tissue) **up to 10,000 times more bacteria can be detected**.

Mixed infections and different bacteria morphotypes can better be identified.

The sensitivity especially of patients with previous antibiotic therapy is improved.



The following implants can be examined using the sonication method:

- Orthopaedic implants (joint prostheses, osteosyntheses)
- Breast prostheses
- Internal neurosurgical shunts
- Cardiac pacemakers and ICDs (implantable cardioverter/defibrillator devices)
- Similar implants that can be removed aseptically from the body

The following materials cannot be examined with the sonication:

- Bone fragments (e.g. sequestrum)
- Soft tissue

The following materials can only be examined to a limited extent with sonication:

Implants taken from primarily non-sterile areas (e.g. VAC sponges, vascular catheters, external cerebrospinal fluid drains, etc.) can be examined using the sonication method, but the limit values of microorganisms cannot be applied.



BactoSonic BS 14.2

Type	Internal tank dimensions l x w x d [mm]	Capacity [l]	External dimensions l x w x h [mm]	Ultrasonic peak power* [W]	Ultrasonic nominal power [W]	Heating power [W]	Outlet ball valve
BactoSonic	325 x 300 x 150	13.5	355 x 325 x 305	800	200	–	G ½

*corresponds to 4-times nominal power

BactoSonic 14.2, consisting of:

- Ultrasonic bath BS 14.2
- Wire frame for foil test FT 14
- Standard operating procedures
- 1 bottle TICKOPUR R 33
(concentrat for producing contact liquid)
- Implant boxes (polypropylene)
 - 2 pcs. IB 5, 0,52 l, Internal dim. 125 × 85 × 50 mm
 - 2 pcs. IB 6, 0,6 l, Internal dim. Ø 120 × 55 mm
 - 1 pc. IB 10, 1,0 l, Internal dim. 255 × 95 × 43 mm
 - 1 pc. IB 18, 1,8 l, Internal dim. 185 × 120 × 80 mm
 - 1 pc. IB 20, 2,0 l, Internal dim. 112 × 80 × 265 mm
- Container carriers BT 5, BT 6, BT 10,
BT 18 (polycarbonate)
GH 14 (stainless steel)



BS 14.2



Container carrier BT 5,
Implant box IB 5



Container carrier BT 6,
Implant box IB 6



TICKOPUR R 33 – 1 l



Container carrier BT 10,
Implant box IB 10

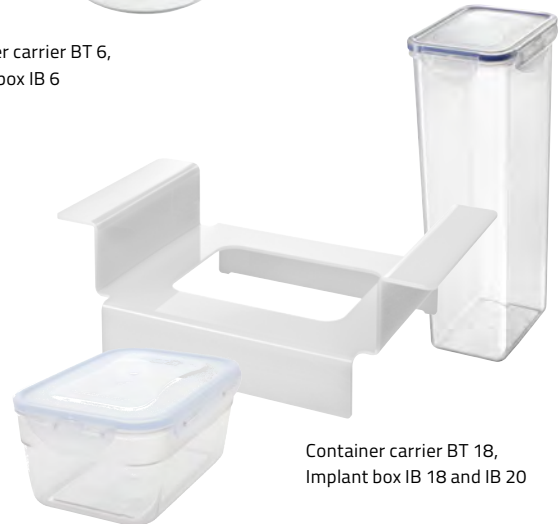

Container carrier BT 18,
Implant box IB 18 and IB 20



Wire frame for foil test FT 14



Utensil holder GH 14

Agents for cleaning and disinfection



TICKOPUR and STAMMOPUR

Cleaning and disinfection agents
for standard use and cleaning
applications

[from page 74](#)

05



Shelf life of disinfectants and detergents

Notes on long-term usability and storage of the agents.

[page 80](#)



Dosage calculator

Avoid over- or under-dosing with our convenient dosage calculator..

[page 80](#)



FAQ Agents

The most frequently asked questions about our agents and their application.

[page 81](#)

TICKOPUR and STAMMOPUR

Cleaning and disinfection agents for standard use and cleaning applications

BANDELIN provides specially-developed agents for numerous use cases, which have been successfully used for many years in a wide range of applications. The cleaners are biodegradable and therefore easy to dispose of.

Selection of the agent, the dosage, the sonication time and the process temperature must be selected according to the application. The material compatibility must always be taken into account when selecting agents.

For optimum results when cleaning the ultrasonic bath, especially formulated detergents are necessary alongside the ultrasonic output, temperature and time. Drinking water alone, without the addition of detergents, does not clean!

An overview of other products that go beyond the applications mentioned here in terms of standard use, is available in our brochure "Cleaning agents and disinfectants for use in ultrasonic baths".

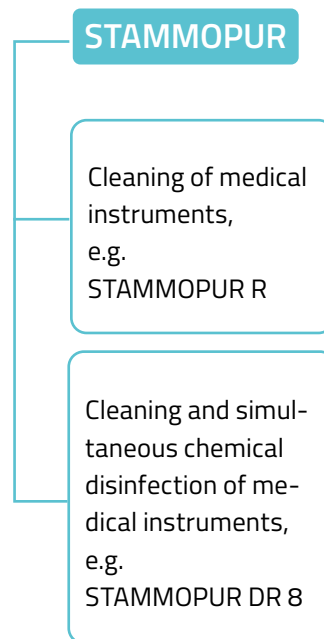
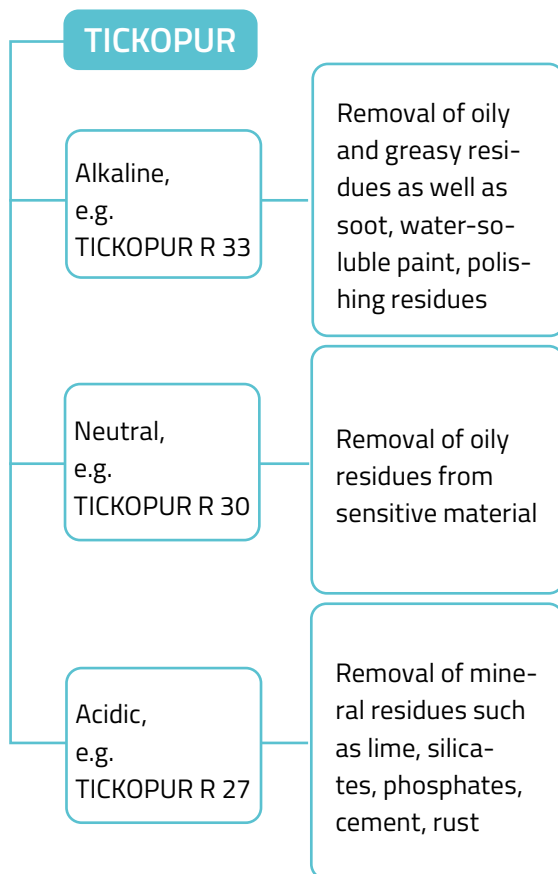

All products are available in several container sizes, here 2, 5 and 10 l

Demulsifying cleaners

Greases and oils float on the surface and are therefore easy to separate.



Special feature of TICKOPUR R 33:

This is a cleaning agent with mainly emulsifying properties. If the solution is not exposed to ultrasound for a longer period of time, a demulsifying effect will occur in the cleaning solution, which can be used when using oil separators.

Emulsifying cleaners

Greases and oils removed from the parts surface are bound by the cleaners and kept in suspension. No re-contamination takes place when the cleaned parts are removed from the bath liquid.

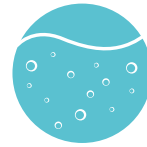

Note for STAMMOPUR 24:

Since this is a cleaning agent and disinfectant, there is no need to classify it in terms of emulsifying or demulsifying properties.

TICKOPUR R 33

Universal cleaner – concentrate

Removes general soiling, machining residues, oil and grease-like residues, gumming, waxes, pigments, ink, soot, light combustion and coking residues, distillation residues, organic and inorganic metal residues (including light metal), glass, ceramics, plastics, rubber, e.g. workpieces and tools from machining, device components, optical glasses, tools, saw blades, E-filters, eyeglasses, laboratory glassware, analysis sieves, micro-titer plates, tableting stamps, work safety goggles and respiratory masks.

Parts made of aluminium, tin and zinc are not to be sonicated/inserted for longer than 3 minutes at max. 50 °C. Then continue to treat under visual control (material change). Brass and copper may discolour.

- EXAM-inspected
- Gentle to material
- With corrosion protection

Active agent base: Tensides

Mildly alkaline, pH 11 (1% in DI water)

Application in the ultrasonic bath:

3 – 5 % • 1 – 10 min

Application without ultrasound:

3 – 20 %



Litres	1	2	5	10	200
Code No.	830	883	831	6023	837

TICKOPUR R 30

Neutral cleaner – concentrate

Removes light residues from machining, oily and grease-like soiling, light soot, dust from metal (including light metal), glass, ceramics, plastics, rubber, e. g. workpieces and tools from machining, components of devices, optical glasses, laboratory goggles, screws, sieves, spindles, pipettes.

- With corrosion protection
- Gentle to material
- Emulsifying

Active agent base: Tensides
Neutral, pH 7 (1% in DI water)

Application in the ultrasonic bath:
1 – 5 % • 1 – 10 min

Application without ultrasound:
1 – 10 %

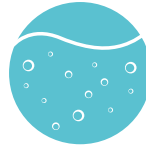

Litres	1	2	5	10	200
Code No.	810	879	811	6021	814

TICKOPUR R 27

Special cleaner – phosphoric acid base – concentrate

Removes strong mineral deposits such as limescale, silicates, phosphates, cements as well as rust, temper colours, metal oxides, grease and oil films from stainless steel, precious metals, glass, ceramics, plastics, rubber, e.g. fittings, nozzles, filters, laboratory goggles, pipettes, aerators, pump housings, valves.

Not for light metals, tin, zinc. Be careful with damaged chrome plating. For steel: material change possible depending on alloy.

- Emulsifying

Active agent base: Phosphoric acid, tensides
Acidic, pH 1.8 (1% in DI water)

Application in the ultrasonic bath:
5 % • 2 – 10 min

Application without ultrasound:
10 – 20 %

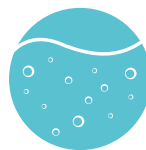

Litres	1	2	5	10	200
Code No.	815	874	816	6020	–

TICKOPUR RW 77

Special cleaner – with ammonia
– concentrate

Removes gumming, soot, pigments, oxides, machining residues, greases, oils, waxes, coatings, flux, combustion residues from steel, stainless steel, non-ferrous metal (brass, copper), glass, ceramics, plastics, rubber, e.g. analysis sieves, tools and tool parts, device components.

Alkali-sensitive materials can be corroded.
Caution with light metals, especially aluminium:
Reduce the sonication to a minimum (< 3 min).

- Phosphate-free
- Emulsifying

Active agent base: Tensides, ammonia
Mildly alkaline, 10.4 (1% in DI water)

Application in the ultrasonic bath:
5 % • 1 – 10 min

Application without ultrasound:
10 %

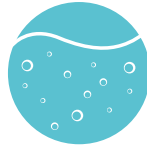

Litres	1	2	5	10	200
Code No.	870	898	871	6026	–

TICKOPUR R 60

Intensive cleaner – highly alkaline
– concentrate

Removes coking residues, gumming, soot, greases, oils, waxes, pigments, coating, machining residues, 3D-printing support materials, residues of incinerated glue and plastic, light paint and dye residues from steel, stainless steel, precious metal, glass, ceramics, plastics, rubber, e.g. 3D prints, laboratory glassware, filters, doctor blades, saw blades, nozzles, vulcanising moulds.

Not for alkali-sensitive materials such as light metals, tin, zinc and non-ferrous heavy metals.

- Free of phosphates and silicates
- Emulsifying

Active agent base: Sodium hydroxide, tensides
Strongly alkaline, pH 12.3 (1 % in DI water)

Application in the ultrasonic bath:
2 – 20 • 1–10 min

Application without ultrasound:
10 – 30 %

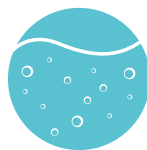

Litres	1	2	5	10	200
Code No.	820	896	818	6025	–

TICKOPUR TR 3

Special cleaner – citric acid base – with corrosion protection – concentrate

Removes mineral residues, flash rust, oxides, machining residues, oil and grease-like residues, light combustion and coking residues, distillation residues, organic and inorganic metal residues (including non-ferrous and light metals), glass, ceramics, plastics, rubber, e.g. machining parts and tools, device components, filters, laboratory goggles, optical glasses.

Parts made of aluminium, tin and zinc are not to be sonicated/inserted for longer than 3 minutes at max. 50 °C. Then continue to treat under visual control (material change). Brass and copper parts are slightly lightened.

- Phosphate-free
- With corrosion protection
- Emulsifying

Active agent base: Citric acid, tensides
Mildly acidic, 2.8 (1% in DI water)

Application in the ultrasonic bath:
5 % • 1 – 10 min

Application without ultrasound:
1 – 20 %

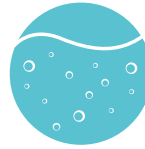

Litres	1	2	5	10	200
Code No.	913	923	935	6016	973

TICKOPUR TR 13

Intensive cleaner – alkaline – concentrate

Removes gumming, combustion and coking residues, machining residues, soot, greases, oils, waxes, pigments, coating, light flash rust from steel, stainless steel, precious metal, glass, ceramics, plastics, rubber, e.g. analysis sieves, laboratory goggles, device components, tool parts, machining tools, saw blades fuel injectors.

Not for alkali-sensitive materials such as light metals, tin, zinc and non-ferrous heavy metals.

- Silicate-free
- Demulsifying

Active agent base: Tensides, alkalis
Alkaline, pH 12 (1% in DI water)

Application in the ultrasonic bath:
0,1 – 10 % • 1–10 min

Application without ultrasound:
1 – 20 %



Litres	1	2	5	10	200
Code No.	844	872	848	6018	853

STAMMOPUR 24

Intensive cleaning and disinfection – concentrate

Agent for cleaning, disinfectant cleaning and disinfection of laboratory instruments, laboratory equipment and its components, respiratory masks, PPE made of rubber, silicone, metal, plastic, porcelain and glass.

Use disinfectant carefully. Always read the label and product information before use N-No.: N-69946.

MD Can also be used for the reprocessing of medical devices such as instruments and accessories.

- VAH certified, EXAM-assessed
- Can be rinsed off without leaving residue
- Free from aldehydes, chlorine and phenols
- No adverse effect on the lifespan of respiratory masks

Active agent base: Amines, propionates
Mildly alkaline, pH 9.4 (1% in DI water)

Application in the ultrasonic bath:

1 % · 15 min

2 % · 5 min

Bactericidal, yeasticidal, limited virucidal incl. H5N1

Application without ultrasound:

1 % · 60 min bactericidal, yeasticidal

2 % · 30 min and

3 % · 15 min bactericidal, yeasticidal, limited virucidal incl. H5N1



Litres	1	2	5	10	200
Code No.	–	977	978	6037	–

Dosing aids

Dosing pumps

This enables the convenient removal of cleaning agents and disinfectants from the canisters, and spillage is reliably prevented.

	Using with	Code No.
Pump ①	5-l-jerrycan	268
Pump ①	10-l-jerrycan	2660
Measuring beaker ②	100 ml	294

Measuring beakers

For accurate dosing of the cleaning agent and disinfectant volumes taken from the dosing table.



Shelf life of disinfectants and detergents

Disinfectants

The shelf life of originally sealed agents by DR. H. STAMM GmbH is three years from the date of manufacture, in compliance with the generally accepted storage conditions. The expiry date is stated on the label under  with year/month.

Cleaning and deoxidising agents

The shelf life of originally sealed cleaning and deoxidising agents by DR. H. STAMM GmbH is at least six years from the date of manufacture, in compliance with the generally accepted storage conditions, and is specified in the form YYMMDD after the designation LOT.

Storage conditions

The packages should be stored at room temperature in well-closed, dry and clean condition.

A change due to frost is not to be expected. After removing the product, the packaging must be sealed. A slight change in colour during longer-term storage of some products is dependent on the raw material and has no impact on effectiveness.

Since compliance with the storage conditions is beyond our control, we cannot guarantee the minimum storage period of the individual products.

Dosage calculator

The decisive factor for successful ultrasound use is the cleaning agent and/or disinfectant that is used. Correct dosage of the concentrate is crucial.

Too low a dosage will impair the effectiveness of the product. For this reason, underdosing should never occur, especially not in medical applications.

Overdosing, however, means unnecessary waste of the product.

You can avoid both situations by using the dosage calculator,

www.bandelin.com/en/service/dosing-calculator/.

Ensure that your ultrasound cleans effectively, economically and in an environmentally friendly manner.

After entering the desired concentration and quantity of working solution to be prepared, the dosage calculator shows how much concentrate and water is required.

The concentration required depends on the application to be performed. Detailed information can be found in the instructions for use of the respective agent.

The quantity of working solution relates to the operating volume of the respective device. The operating volume designates the filling volume of the tank up to the filling level mark. You can find it in the respective instructions for use.

FAQ – Agents

Should I rinse off the cleaning solution?

Yes, the cleaning concentrates are aqueous agents. The resulting solutions should therefore be removed from all water-resistant surfaces without leaving any residue by means of thorough aqueous rinsing.

When will the cleaning liquid become cloudy?

This can occur if using drinking water that is too hard and/or if the dosage is too low.

When do cleaning solutions flocculate?

When preparing the cleaning solutions, make sure to mix manually after adding the concentrate. Ultrasound alone does not lead to sufficient circulation in the solution, so that precipitation or flocculation up to gel formation can occur at the water/concentrate phase boundaries. A simple mixing method can be used once the working solution is prepared: half of the required water is placed in the ultrasonic bath and the concentrate is then added. Ample mixing takes place automatically when the remaining amount of water is added.

Cleaning solutions can flocculate even with certain contaminants if the contaminant reacts with the components of the cleaning solution. The long product life of a solution can also lead to precipitation. Therefore, check the solution regularly and, if necessary, at an early stage.

What does temporary corrosion protection mean for our cleaning agents?

The corrosion protection is active in the bath during sonication, but is removed from the surface of the parts by a subsequent, thorough aqueous rinsing. Rinsing is required in almost all use cases as the cleaning solution with impurities may leave stains on the parts when drying and possibly continue to react with the surface (material corrosion, discolouration).

Am I allowed to add/adjust doses?

Adding or adjusting doses should be avoided as the components of the cleaning solution bind differently, which could lead to a shift in ingredient concentrations with undesired effects after the dose has been adjusted.

Contact liquid for indirect sonication

For the indirect sonication of samples, use an ultrasound-compatible cleaning agent for the bath liquid, to reduce the surface tension. This contributes to the uniform propagation of the ultrasound waves, leads to reproducible results and extends the lifespan of the stainless steel tank.

As an additive for the contact liquid, we recommend
TICKOPUR R 33 – 3%,
TICKOPUR R 30 – 3% or
TICKOPUR TR 3 – 1%.

Further information on indirect sonication can be found on page 18.



Service

We are the specialists for ultrasound in laboratory



Ultrasonic baths for rent

Rent one of our ultrasonic baths
for a specific period only.

[from page 84](#)



Knowledge

Basic knowledge for the use
of ultrasound and ultrasonic baths.

[from page 86](#)

06



Detailed application examples

Application notes of our customers.

[from page 90](#)



FAQ – Ultrasonic baths

The most important questions, shortly answered.

[page 101](#)



Your contact person for the laboratory field

Let yourself be competently and personal advice from our expert.

[page 102](#)

Ultrasonic baths for rent



Do you need an ultrasonic bath for a certain period of time, to clean parts or to check whether ultrasound is the right choice for your process?

We rent out ultrasonic baths in sizes from 0.9 to 90 l operating volume, with suitable accessories.

Interested?

Note: Rentals are only available within Germany.

The rental of ultrasonic baths is only offered to commercial customers. The minimum rental period is one week.



A few steps to the rental unit

1

Select device type from the table (right) or on the website and download the corresponding Download rental agreement. Alternatively, you can request it by phone or e-mail.



For an optimal cleaning result, specially adapted cleaning preparations are necessary. We will be happy to advise you on the selection!

For more information:

www.bandelin.com/en/service/



2 Fill out the rental agreement and return it by mail and send it back. We will get back to you!



3 The ultrasonic bath is delivered at the agreed time and place.



4 After use, you return the device to us together with a completed Certificate of Decontamination.

Download the certificate of decontamination:

www.bandelin.com/fragebogen/Dekontamination_GB_BANDELIN.pdf

Type	Internal tank dimensions l x w x d [mm]	Capacity [l]	Code No.	External dimensions l x w x h [mm]	Ultrasonic peak power* [W]	Ultrasonic nominal power [W]	Heating power [W]	Outlet ball valve
SONOREX SUPER RK								
RK 52 RK 52 H	150 x 140 x 100	1.8	311 164	175 x 165 x 225	240 240	60 60	– 140	– –
RK 100 RK 100 H RK 102 H	240 x 140 x 100	3.0	301 312 303	260 x 160 x 250	320 320 480	80 80 120	– 140 140	– – G ¼
RK 510 RK 510 H	300 x 240 x 150	9.7	327 321	350 x 265 x 300	640 640	160 160	– 400	G ½ G ½
RK 514 RK 514 H	325 x 300 x 150	13.5	277 207	355 x 325 x 305	860 860	215 215	– 600	G ½ G ½
RK 1028 RK 1028 H	500 x 300 x 200	28.0	322 324	535 x 325 x 400	1200 1200	300 300	– 1300	G ½ G ½

SONOREX DIGITEC DT

DT 52 DT 52 H	150 x 140 x 100	1.8	3205 3225	175 x 165 x 230	240 240	60 60	– 140	–
DT 100 DT 100 H DT 102 H	240 x 140 x 100	3.0	3210 3230 3235	260 x 160 x 250	320 320 480	80 80 120	– 140 140	– – G ¼
DT 510 DT 510 H	300 x 240 x 150	9.7	3245 3206	350 x 265 x 300	640 640	160 160	– 400	G ½ G ½
DT 510 F	300 x 240 x 65	4.3	3242	325 x 265 x 195	560	140	–	G ½
DT 514 DT 514 H	325 x 300 x 150	13.5	3250 3211	355 x 325 x 305	860 860	215 215	– 600	G ½ G ½
DT 1028 DT 1028 H	500 x 300 x 200	28.0	3255 3231	535 x 325 x 400	1200 1200	300 300	– 1300	G ½ G ½
DT 1028 F	500 x 300 x 65	9.5	3243	535 x 325 x 205	1280	320	–	G ½

SONOREX DIGIPLUS DL

DL 102 H	240 x 140 x 100	3.0	7180	260 x 160 x 250	480	120	140	G ¼
DL 510 H	300 x 240 x 150	9.7	7183	325 x 265 x 305	640	160	400	G ½
DL 514 BH	325 x 300 x 200	18.7	7185	355 x 325 x 385	860	215	600	G ½
DL 1028 H	500 x 300 x 200	28.0	7186	535 x 325 x 400	1200	300	1300	G ½

*corresponds to 4 times ultrasonic nominal power



SONOREX PR 140 DH

Ultrasonic bath for cleaning of volumetric glassware with lengths up to 755 mm
Code No. 2070



SONOSHAKE

Ultrasonic bath with shaking device for sample preparation

SONOSHAKE Set Code No. 3257
(Ultrasonic bath DT 1038 F and Shaking device SA 1028)
Shaking device SA 1028 Code No. 3249



SONOCOOL

Ultrasonic bath with cooling for analysis laboratories and pathologies

Laboratory Set
Code No. 3500032

KNOWLEDGE

Basic information concerning use

Medium in the ultrasonic bath

Ultrasonic waves do not penetrate the air, a liquid contact medium is fundamentally required.

For improved transmission of the ultrasound, addition of an ultrasound-compatible cleaning agent to the mains/deionised water for preparation of the contact liquid is required (e.g. TICKOPUR R 33 – 1%).



Filling an ultrasonic bath
and dosage of the cleaning agent
[youtube.com/bandelin](https://www.youtube.com/bandelin)



Degassing of the ultrasonic fluid

After filling the ultrasonic bath with mains/fully deionised water and adding the dosed quantity of agent or after a longer holding time, e.g. overnight, the ultrasound must be switched on for a few minutes up to half an hour. This will remove any air bubbles that may impair effectiveness.

Only after the transition from gas to steam cavitation can the ultrasound develop its full effect. This can be observed based on the ultrasonic bath noise: It becomes quieter.

Gas cavitation: Dissolved gases in the liquid fill the cavitation bubbles and lessen the implosion. In this case, the effect of cavitation is greatly reduced. The ultrasonic bath noise is very unpleasant. Gas bubbles concentrate and rise to the surface.

Steam cavitation: Additional cavitation bubbles are suddenly formed by steam, resulting in a heightened implosion. The noise is greatly reduced by shifting to higher frequencies.

NOT to be used directly in the ultrasonic bath

Caution! Unsuitable media can corrode parts and the ultrasonic bath itself!

Solvents (petrol, alcohol, acetone, etc.) may not be used directly in the ultrasonic bath. If used, there is a risk of flammability and explosion! Household cleaners, acids or acidic cleaners may not be used directly in the ultrasonic bath under any circumstances.

The stainless steel of the oscillating tank would be corroded, leading to pitting and ultimately a device defect. Distilled/deionised water has an increased surface tension. This results in an inhomogeneous distribution of ultrasound, i.e. zones with strong and weak intensities. Cavitation erosion is intensified in the strong zones. This accelerates wear.

Notes on indirect sonication, e.g. of samples in laboratory vessels

- 1 Drinking water or distilled/deionised water without cleaning additive results – due to the increased surface tension – in an inhomogeneous ultrasonic field: There are strong and weak zones in the bath and thus different sonication results are obtained in the samples; the process of cavitation erosion in the tank bottom is accelerated in the strong zones. Therefore, an ultrasound-compatible cleaning agent must always be added – depending on the agent, a 1% dosage is sufficient for indirect sonication.
- 2 Please note that different ultrasonic baths can have different power densities in W/L and that the results/sonication times can be different. The same applies to different fill levels in the same tanks.
- 3 Do not position the vessels above the outlet or too far outwards (toward the edge of the tank) – hardly any cavitation takes place here. The foil test can be used to monitor the distribution in the bath.
- 4 Many processes require constant temperatures. Crushed ice is often used in practice for the required cooling. It must never be placed under the reaction vessels, as otherwise the ultrasound will not be transmitted to the vessels. We recommend our LA-BOCOOL 400 for cooling the bath liquid.
- 5 The bottom of the sonication vessels should not be too thick.
- 6 The sonication vessels should preferably be made of glass, since this allows for significantly better ultrasound transmission as compared to plastic.

Heating by ultrasound

Ultrasound baths with heating have a temperature control. When the target temperature is reached, the heating switches off. The temperature in the bath still increases, however, due to the ultrasound: Mechanical energy is converted into thermal energy. For example, if a working temperature of 20 °C is required, special external cooling systems must be used. A cooling coil alone, connected only to the water circuit, is not sufficient.

The heating of the liquid can be determined with the known energy formula $P = \frac{\Delta Q}{\Delta T} = \frac{c \cdot m \cdot \Delta t}{\Delta t}$.

The specific heat capacity of the liquid acts as a multiplier. Combustible liquids possess a heat capacity that is approx. a quarter less than that of water. As a result, the heating of the liquid is four times higher during sonication. Therefore, the direct use of solvents in the ultrasonic bath is not permitted! The flash point is reached or exceeded in a very short time.

Therefore, the use of small quantities of flammable liquids in appropriate inset beakers is **only permitted in the case of indirect sonication**. In such cases, country-specific regulations must be observed.

Heating by ultrasound at a power density of 20 W/l

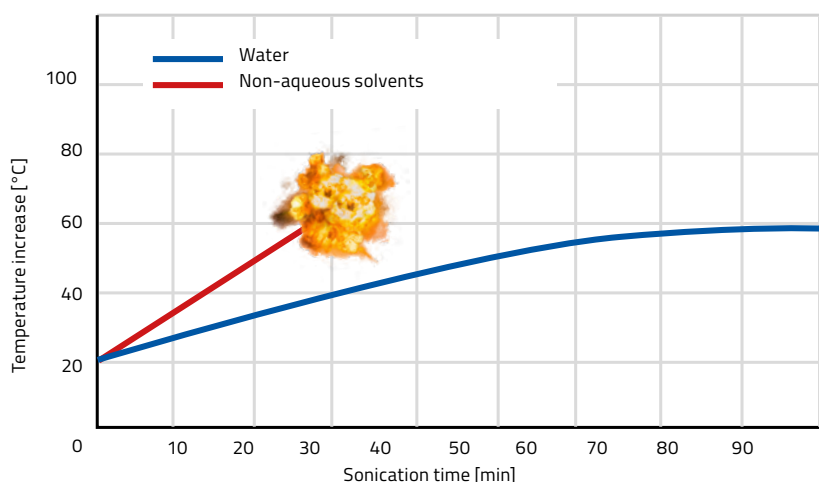

Prerequisites for trouble-free operation of an ultrasonic bath

Correct fill level

The lower the fill level, the higher the power density [W/L]. This increases the bath temperature considerably faster. There is a risk of dry running, as the fill level is reduced by evaporation.

Checking the bath temperature

Overheating or very rapid cooling can cause damage to the adhesion of the vibrating elements.

Avoiding an overload

Overloading (> 40% of the filling volume) can cause sound absorption. The result is an overheating of the transducers.

Suitable bath liquid

The use of unsuitable liquids, especially solvents, leads to overheating. Acidic liquids cause pitting corrosion in the oscillating tank.

Ensuring that the device functions correctly

Ultrasound cleans, homogenises, dissolves and disperses through cavitation. The parts to be cleaned are only exposed to cavitation for a short time; the oscillating tank is permanently exposed, however. This means that wear cannot be avoided. Cavitation erosion is natural wear and is not covered by the warranty. If the bath is used in accordance with the instructions for use, the lifespan can be significantly longer than 1000 h. For a long lifespan, we recommend replacing the cleaning liquid more frequently and cleaning the oscillating tank thoroughly on a regular basis. In doing so, remains left in the tank bottom such as metal particles or polishing agent residue should be removed in order to prevent contact corrosion with the stainless steel. Unsuitable cleaners and aggressive impurities increase the wear. In the worst case, the lifespan will only be a few hours. The ultrasonic cleaning tank is made of stainless steel. The special treatment of the stainless steel surface provides corrosion protection, provided that this protection is not destroyed by foreign metal particles or rust. If the passivation layer is destroyed, the stainless steel rusts or corrodes at certain points and is quickly destroyed electrochemically. Because this attack occurs only in point form, it is also called pitting corrosion.

The causes include:

- Entry of rust particles from the hose system: The drinking water contains metal salts (such as calcium, magnesium = hardening agents) and other salts (including iron salts). With a correspondingly long exposure time, these salts result in extraneous rust on stainless steel surfaces. This is only prevented by adding an ultrasound-compatible cleaning agent to the drinking water. Most cleaning agents contain ingredients that hold the described substances in solution and can prevent an attack by extraneous rust. In addition, the formation of ultrasound cavitation in such a liquid is significantly better than in pure, hard drinking water.
- Water containing iron or rust, steam containing rust
- Cleaning of non-corrosive steel parts whose protective layer has been destroyed

To remove extraneous rust from the tank bottom, TICKOPUR R 27 (undiluted) is applied to a damp sponge and spread over the surface. After a treatment time of approx. 1–2 minutes, the surface must be thoroughly rinsed with water. In the case of heavier extraneous rust, the treatment time should be increased to max. 15 minutes.

Ultrasonic baths require no maintenance. Repairs may only be performed by BANDELIN or authorised, qualified personnel.

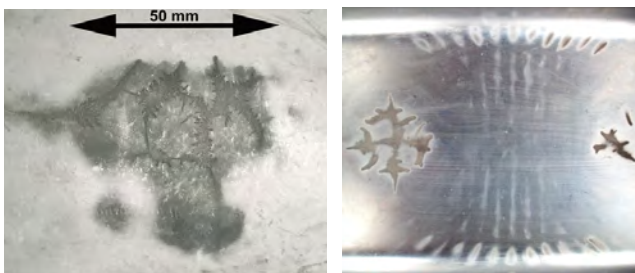

Examples of cavitation erosion at the bottom of the tank

Performance check via a foil test

The international standard IEC 886 contains instructions on checking the function of an ultrasonic bath. A foil test is recommended – at initial commissioning, then at regular intervals (e.g. quarterly). The frequency of checks is the responsibility of the user. The foil test is a simple procedure to demonstrate the intensity and distribution of cavitation in an ultrasonic bath. It involves stretching aluminium foil over a foil test frame. Depending on the duration, this foil is perforated to a certain degree or destroyed by cavitation during ultrasonic treatment in the bath. The “hole pattern” can be used to assess the distribution and intensity of the cavitation.

For purposes of reproducibility, it is important that the test conditions always remain constant:

- Fill level in the oscillating tank (two thirds)
- Temperature of the tank contents
- Degassing time, if necessary (degassing for 5–30 minutes before the test, depending on the contents of the tank). Time may need to be extended in the case of acidic cleaning solutions.
- Frame positioning
- Foil properties (thickness, surface)
- Sonication time
- Concentration and type of ultrasound agent



Testing an ultrasonic bath
with the foil test
[youtube.com/bandelin](https://www.youtube.com/bandelin)



Foils can be archived in a suitable way (scanning, photos, etc.). This allows foils to be compared at any time. The perforated areas of all foils should exhibit approx. the same dimensions and distribution – the results are never identical. It is only a qualitative assessment, not a quantitative one.

A process validation, e.g. for the reprocessing of medical devices, can only be achieved by conducting regular foil tests. Different FT foil test frames can be ordered from the manufacturer for the foil test (for a fee). The foil test frames are designed for a wide range of tank dimensions.

Aluminium household foil is also required to conduct the test and is not included in the delivery.

Medium for the foil test: In order to obtain a sufficiently strong cavitation, the foil test also requires a reduction in the surface tension of the water used, with the aid of surfactant agents.

We recommend the following ultrasound agents: TICKOPUR R 33, TICKOPUR R 30, TICKOPUR TR 7, STAMMOPUR DR 8, STAMMOPUR R, TICKOMED 1. If none of these products are available, a neutral or mildly alkaline agent that does not destroy aluminium may be used. The product must be approved by the manufacturer for use in ultrasonic baths.



Foil stretched on a foil test frame

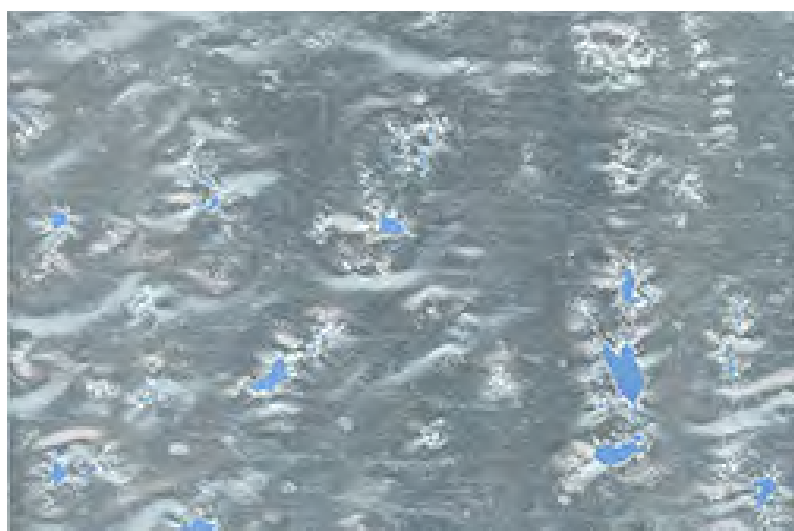

The perforation in the foil after the foil test can be used to check the intensity and functionality of the ultrasonic bath

Detailed application examples

Application notes from our customers

Type	No.	Application	Method notes	Working area	Sub-area	Type of company
Others	A-1	Decontamination of hair samples, drugs adhering outside	Ultrasonic bath: RK 100, without heater Liquid in the bath: distilled / deionised water with TICKOPUR R 33 – 1 % t = 7 min Remark: wash step before extraction necessary	Analysis and laboratory companies		University/institute
Others	A-2	Separation of salts from paper surfaces tests for paper (size press) for IC	Ultrasonic bath: with heater Liquid in the bath: distilled / deionised water with TICKOPUR R 33 – 1 % Indirect sonication Sample vessel: Erlenmeyer flask (250 ml) Insert basket K + Spring clamps EK t = 20–30 min T = room temperature	Paper		Industry
Others	A-3	Separation of digested proteins, peptides from gel from gel-electrophoresis for LC-MS, TOF-MS for gel-electrophoresis	Ultrasonic bath: without heater Liquid in the bath: tap water with TICKOPUR R 33 – 3 % Indirect sonication Sample vessel: Eppendorf-tubes in a styrofoam sheet Medium: aqueous solution, sometimes with a detergent t = 10 min (pulsed) T = room temperature (z. T. Eis in die Kontaktflüssigkeit gefüllt) Remark: proteins/peptides dissolve.	Biotechnology	Molecularbiology	University/institute
Degassing	D-1	Carbon dioxide in mineral water for determination AAS potassium	Bad: without heater Liquid in the bath: tap water with TICKOPUR R 33 – 3 % Indirect sonication Sample vessel: Erlenmeyer flask t = 1 min T = room temperature	Analysis and laboratory companies		Service provider
Degassing	D-2	HPLC eluent	Ultrasonic bath: RK 510 H, with heater Liquid in the bath: water with TICKOPUR R 33 – 3 % Indirect sonication Sample vessel: laboratory flask in an insert basket	Cosmetics		Industry
Degassing	D-3	HPLC eluent, buffer and solvent	Ultrasonic bath: square base area, with heater Liquid in the bath: water with TICKOPUR R 33 – 3 % Indirect sonication Sample vessel: 2 x 500-ml-flasks t = 20–30 min Remark: optical test!	Analysis and laboratory companies		Service provider
Degassing	D-4	Degassing of shampoo or bath foam for sample preparation, e.g. for measuring the viscosity	Ultrasonic bath: flat, without heater Liquid in the bath: water with TICKOPUR R 33 – 3 % Indirect sonication Sample vessel: with quick release closure (200 ml), holder Sample volume: 100 ml t = approx. 5 min	Cosmetics		Industry
Degassing	D-5	Mineral water for determination of heavy metals by ICP-M	Bad: without heater Liquid in the bath: water with TICKOPUR R 33 – 3 % Indirect sonication Sample vessel: Erlenmeyer flask Sample volume: 100 ml t = approx. 30 s	Investigation office	Environment (Heavy metals, soils)	Öffentliche Einrichtung

Type	No.	Application	Method notes	Working area	Sub-area	Type of company
Degassing	D-6	HPLC eluent	Ultrasonic bath: RK 156 or RK 1028, without heater Liquid in the bath: water with TICKOPUR R 33 – 3 % Indirect sonication Sample vessel: 1-l-Laboratory flask in an insert basket t = 10 min	Cosmetics		Industry
Degassing	D-7	Solvents, mixed (alcohol-water mixtures)	Ultrasonic bath: RK 100, without heater, with insert basket Liquid in the bath: water with TICKOPUR R 33 – 3 % Indirect sonication t = 30 min	Biotechnology		Uni/FH/ Institut
Degassing	D-8	HPLC eluent	Ultrasonic bath: RK 52 H, with heater Liquid in the bath: water with TICKOPUR R 33 – 3 % Indirect sonication Sample vessel: 1-l-laboratory flask in a holder	Chemistry	Biotechnology	Uni/FH/ Institut
Degassing	D-9	HPLC eluent	Ultrasonic bath: RK 1028 H, with heater Liquid in the bath: water with TICKOPUR R 33 – 3 % Indirect sonication Sample vessel: 1-l-Laboratory flask in an insert basket t = 15 min	Analysis and laboratory companies	Foodstuffs	Service provider
Degassing	D-10	Molasses samples	Ultrasonic bath: DT 1028 H, with heater Liquid in the bath: water with TICKOPUR R 33 – 3 % Indirect sonication Sample vessel: glass beaker (V= 200 ml) in an insert basket t = ca. 2–4 min T = room temperature Requirement: ICUMSA (sugar)	Analysis and laboratory companies	Foodstuffs	Service provider
Degassing	D-11	HPLC eluent	Ultrasonic bath: RK 1028 H, with heater Liquid in the bath: water with TICKOPUR R 33 – 3 % Indirect sonication Sample vessel: 1-l-Laboratory flask in an insert basket t = 15 min	Analysis and laboratory companies	Foodstuffs (Vitamins)	Service provider
Degassing	D-12	HPLC eluent	Ultrasonic bath: RK 255, without heater Liquid in the bath: water with TICKOPUR R 33 – 3 % Indirect sonication Sample vessel: 1-l-Laboratory flasks or 2-l-Laboratory flasks in an insert basket For HPLC: t = 15 min	Toxicology		Service provider
Degassing	D-13	HPLC eluent, LC-MS-solvent	Ultrasonic bath: RK 100, without heater Liquid in the bath: water with TICKOPUR R 33 – 3 % Indirect sonication Sample vessel: 1-l-Laboratory flasks in insert basket (sometimes adding of ice to the contact liquid = cooling) t = 15 min	Analysis and laboratory companies		Service provider
Extraction	E-1	Analytes from Dried-Blood-Spot-Matrix in buffer for LC-MS (Dried-Blood-Spot-Matrix for sample transport)	Ultrasonic bath: without heater Liquid in the bath: water with TICKOPUR R 33 – 3 % Indirect sonication Dried-Blood-Spot-Matrix for sample transport dried blood on a filter + buffer Sample vessel: Eppendorf-Tubes or vials in a holder t = 10–20 min T = room temperature Remark: Defined quantity of liquid can be absorbed.	Toxicology	Analysis and laboratory companies for Medicine	

Type	No.	Application	Method notes	Working area	Sub-area	Type of company
Extraction	E-2	Building pollutants (wall papers, jointing material) and air analysis: PCB, wood preservatives for determination by GC-MS, compounds typically contained in explosives from soils, air analysis by silica gel as adsorbents – desorption of analytes in solvents in an ultrasonic bath	<p>Ultrasonic bath: with heater Liquid in the bath: water with TICKOPUR R 33 – 3 % Indirect sonication</p> <ul style="list-style-type: none"> building pollutants: Sample vessel: vials with quick release closure (22 ml) in a holder t = 20 min–2 h T = room temperature Medium: different solvent, z. B. hexane, hexane-acetone, Dichloromethane soils containing explosives: T = 40 °C solvent: water air samples: Sample vessel: vials with quick release closure adsorbents: silica gel + acetonitril t = 30 min 	Analysis and laboratory companies	Environment (air, building contaminants)	Service provider
Extraction	E-3	Soil / waste for determination by GC-MS, asphalt cores, PAHs	<p>Ultrasonic bath: DT 1028 F (flat), without heater Liquid in the bath: water with TICKOPUR R 33 – 3 % Indirect sonication</p> <ul style="list-style-type: none"> soil / waste: batch weight: 5 g sample + 20–30 ml solvent Medium: hexane, hexane and acetone Sample vessel: vials with quick release closure t = 10–15 min T = room temperature (too warm for analysis) asphalt samples: T = room temperature 	Analysis and laboratory companies	Environment (soils, waste)	Service provider
Extraction	E-4	Analytes from heart muscle tissue (preclinical trials), analytes from animal tissue specimen	<p>Ultrasonic bath: without heater Liquid in the bath: water with TICKOPUR R 33 – 3 % Indirect sonication 50 mg in 100 µl (pulpy mass)–shock freezing (to prevent crystallisation) recommended by Essay: V = 500 mg in 500 µl, crushed, in cold environment t = 30 s – different cycles T = room temperature Medium: aqueous</p> <ul style="list-style-type: none"> animal tissue specimen: Remark: closed cover, analyte concentration 0–10 ng in 50 mg tissue 	Biotechnology		Industry
Extraction	E-5	Water-soluble substances in food samples (cheese, sugar) for sugar enzymatics	<ul style="list-style-type: none"> cheese <p>Ultrasonic bath: with heater Liquid in the bath: tap water with TICKOPUR R 33 – 3 % Indirect sonication Sample vessel: volumetric flask or Erlenmeyer flask in an insert basket or holder Water-soluble substances in iced water Medium: water / methanol t = 15 min T = room temperature or 50–60 °C</p>	Analysis and laboratory companies	Foodstuffs	Service provider
Extraction	E-6	Different environmental, pharmaceutical or chemical samples for analysis: AAS, ICP, NMR, IC	<p>Ultrasonic bath: with heater Liquid in the bath: tap water with TICKOPUR R 33 – 3 % Indirect sonication Sample vessel: NMR vials, small volumetric flask, Falcon tubes (10–50 ml), beakers in an insert basket Medium: different solvents depending on the method (e. g. chloroform, DMSO, acetonitrile) T = ca. 30 °C (sometimes 50 °C) Remark: formation of aggregates should be prevented</p>	Analysis and laboratory companies	Environment, chemistry, pharmacy	Service provider

Type	No.	Application	Method notes	Working area	Sub-area	Type of company
Extraction	E-7	Desagglomeration of soil and clay for sample preparation and particle size analysis	Ultrasonic bath: with heater Liquid in the bath: tap water with TICKOPUR R 33 – 3 % Indirect sonication Remark: Fractions should remain in their natural conditions.	Analysis and laboratory companies		Service provider
Extraction	E-8	Soil / waste – determination of PAHs and PCBs (organic substances - as a substitute for Soxhlet extraction)	Ultrasonic bath: with heater Liquid in the bath: tap water with TICKOPUR R 33 – 3 % Indirect sonication Sample vessel: Vials (10–20 ml) in a plastic holder Medium: acetonitrile, n-Hexan t = 1 h T = room temperature (Liquid in the bath warms-up by ultrasound!) Remark: as a substitute for Soxhlet-extraction! Interlaboratory tests: much more solvent efficient.	Environmental analysis and engineering		Service provider
Extraction	E-9	Hair for drug analysis for forensic and clinical purposes (blood, urine, serum by FI-FI extraction or SPE, much more gentle)	Ultrasonic bath: RK 100, without heater Liquid in the bath: tap water with TICKOPUR R 33 – 3 % Indirect sonication Sample vessel: glass vessel (4 ml) in a holder placed into an insert basket t = 1 h	Analysis and laboratory companies		University/institute
Extraction	E-10	Food samples (seeds, flour, baked goods)	Ultrasonic bath: without heater Liquid in the bath: tap water with TICKOPUR R 33 – 3 % Indirect sonication Sample vessel: glass beaker (V up to 50 ml) Medium: solvent t = 15–30 min	Analysis and laboratory companies		Commercial analysis lab
Extraction	E-11	Substances contained in plants - powdered - quantitative analysis	Ultrasonic bath: with heater Liquid in the bath: tap water with TICKOPUR R 33 – 3 % Indirect sonication Sample vessel Volumetric flask, Erlenmeyer flask in a holder placed into an insert basket t = 5–15 min T = 40 °C Remark: sample (extract) powdered. Heat should be dissipated by cooling – sensitive sample material!	Biotechnology		University/institute
Extraction	E-12	Drugs, tablet residues in the stomach contents (homogenising)	Ultrasonic bath: RK 100, without heater Liquid in the bath: tap water with TICKOPUR R 33 – 3 % Indirect sonication Sample vessel: lab flasks (10 ml) Medium: alcohols t = 15 min T = room temperature	Toxicology		University/institute
Extraction	E-13	Soil /waste for LC-MS, HPLC, LC	Ultrasonic bath: without heater Liquid in the bath: tap water with TICKOPUR R 33 – 3 % Indirect sonication Sample vessel: flasks with quick release closure (up to 100 ml), centrifuge vials t = 30 min (15 to 60 min) Remark: good results in interlaboratory tests	Analysis and laboratory companies	Environment (soils, waste)	Service provider
Extraction	E-14	Soil samples for organic analysis (in vials or on glass surfaces, GC-MS e. g.; Surface samples taken by means of wipes	Ultrasonic bath: without heater Liquid in the bath: tap water with TICKOPUR R 33 – 3 % Indirect sonication Liquid in the bath: n-Hexan, DI water Sample vessel: glass beakers (100 to 200 ml) placed into an insert basket t = 1 to 30 min (depending on analysis focus)	Analysis and laboratory companies	Environment (soils, waste)	Service provider

Type	No.	Application	Method notes	Working area	Sub-area	Type of company
Extraction	E-15	Suspensions with pharmaceutical samples of any kind, vitamins - sample preparation for GC and HPLC	Ultrasonic bath: 20 x 15 cm, without heater Liquid in the bath: tap water with TICKOPUR R 33 – 3 % Indirect sonication Sample vessel: 10 ml / 100 ml volumetric flasks Medium: aqueous liquids, sometimes mixed with methanol t = as needed, sometimes for longer periods T = room temperature Remark: adding of ice to the contact liquid	Analysis and laboratory companies	Pharmacy	Service provider
Extraction	E-16	Soil / waste for determination of PAHs, PCBs, Mineral oil hydrocarbons; analytes from asphalt	Ultrasonic bath: without heater Liquid in the bath: tap water with TICKOPUR R 33 – 3 % Indirect sonication Sample vessel: volumetric flask (25 ml), glass beaker (20–100 ml) in an insert basket Medium: Hexan t = 5–10 min (cooling by adding ice to the contact liquid) T = room temperature	Analysis and laboratory companies		Service provider
Extraction	E-17	Analytes from hair for determination of drugs	Ultrasonic bath: without heater Liquid in the bath: tap water with TICKOPUR R 33 – 3 % Indirect sonication Sample vessel: glass vials (10 ml) t = 2–4 h	Toxicology		University/institute
Extraction	E-18	Food and cosmetic samples for determination of residues by LC-MS, HPLC - powdered plant drugs	Ultrasonic bath: with heater Liquid in the bath: tap water with TICKOPUR R 33 – 3 % Indirect sonication Sample vessel: volumetric flask (10 ml), Falcon tubes (15–50 ml), Eppendorf Cups, in holders, Medium: methanol/ethanol, ether (for samples that need to be degreased) t = max. 30 min T = 40 °C Remark: Ultrasonic bath partly better than a shaker	Toxicology		University/institute
Extraction	E-19	Soil/waste: determination of PAHs and PCBs (PAH sample separately and combination PAHs, PCBs)	Ultrasonic bath: with heater Liquid in the bath: Tap water with TICKOPUR R 33 – 3 % Indirect sonication Sample vessel: volumetric flask (250 ml) in a holder placed into an insert basket Medium: n-Hexan T = room temperature	Analysis and laboratory companies	Environment	Analysis
Dissolving	L-1	Substances for practical course: Copper-glycine complex and other organic solids	Ultrasonic bath: without heater Liquid in the bath: tap water with TICKOPUR R 33 – 3 % Indirect sonication Remark: dissolved particles into heat	Biotechnology		University
Dissolving	L-2	Cosmetic samples: shampoos, conditioners without solvents, creams, lotions with solvents	Ultrasonic bath: with heater Liquid in the bath: tap water with TICKOPUR R 33 – 3 % Indirect sonication Sample vessel: volumetric flask, glass beaker, measuring cylinder (10-50 ml, usually 20 ml) in an insert basket Medium: acetonitrile, methanol, ethanol t = 2 x 15 min T = room temperature	Cosmetics		Industry

Type	No.	Application	Method notes	Working area	Sub-area	Type of company
Dissolving	L-3	Residue analysis - veterinary drug analysis, standard substances for LC-MS e. g., poorly soluble buffer substances (potassium buffer), residues LC-MS of processed samples (urine, blood, tissue) after drying in HPLC eluent	<ul style="list-style-type: none"> Urine, blood, tissue Ultrasonic bath: with heater (many applications) Liquid in the bath: tap water with TICKOPUR R 33 – 3 % Indirect sonication Sample vessel: Erlenmeyer flask (V = 100 ml) t = approx. 30 s Sample vessel: hand-tip vials, Eppendorf tubes, test tubes (5–10 ml) Standard: 10-ml-volumetric flasks (or smaller), fixing by hand t = several seconds up to 2 min buffer: 0,5l–1 l t = 10 min Remark: When dissolving the blood samples, a change between ultrasonic bath and VORTEX reactor is necessary for 3 to 4 times.	Investigation office	Veterinary medicines	Öffentliche Einrichtung
Dissolving	L-4	Sample preparation - analytes of ointment drug raw materials, e.g. film former Providon (excipient) for HPLC	Ultrasonic bath: with heater, Liquid in the bath: tap water with TICKOPUR R 33 – 3 % Indirect sonication <ul style="list-style-type: none"> Ointment drug excipients Sample vessel: volumetric flask (25–100 ml), shaking t = 10–30 min T = room temperature to 40°C	Analysis and laboratory companies		Service provider
Dissolving	L-5	Poorly soluble peptides, buffers, salts, standard substances (for quality tests)	Ultrasonic bath: with heater, V = ca. 3 l Liquid in the bath: tap water with TICKOPUR R 33 – 3 % Indirect sonication <ul style="list-style-type: none"> Poorly soluble peptides Medium: formic acid Sample vessel: 1,5 ml Eppendorf tubes up to 50 ml Falcon tubes in plastic holders placed into an insert basket t = 1–10 min T = room temperature <ul style="list-style-type: none"> buffer Sample vessel: 1-l-laboratory flasks T = room temperature	Biotechnology		
Dissolving	L-6	Trace analysis MS	Ultrasonic bath: with heater Liquid in the bath: Tap water with TICKOPUR R 33 – 3 % Indirect sonication Sample vessel: lab vessels placed into an insert basket t = 15 min T = RT Remark: Sample preparation with hydrofluoric acid in special lab vessels, which are then placed into the microwave.	Chemistry	Glass / ceramics	Industry
Dissolving	L-7	Resolubilisation of samples from PCR buffers for MS	Ultrasonic bath: without heater Liquid in the bath: Tap water with TICKOPUR R 33 – 3 % Indirect sonication Sample vessel: volumetric flask t = 15–30 s T = room temperature	Biotechnology		Industry
Dissolving	L-8	Viscose samples, cosmetic samples, e.g. hair conditioners	Ultrasonic bath: flat, without heater Liquid in the bath: Tap water with TICKOPUR R 33 – 3 % Indirect sonication Sample vessel: volumetric flask placed into an insert basket Medium: Water and organic solvents, varying t = 1 min T = room temperature Remark: Viscose samples, dilute if necessary, fill up after one minute!	Cosmetics		Industry

Type	No.	Application	Method notes	Working area	Sub-area	Type of company
Dissolving	L-9	Creams, lotions, surfactants, viscous samples such as hair conditioners	<p>Ultrasonic bath: without heater Liquid in the bath: Tap water with TICKOPUR R 33 – 3 % Indirect sonication Remark: Regulation of the immersion depth with handle adjustment Sample vessel: small vessels with quick release closure, lab vials, smaller sample weight vessels (50–100 ml), placed into an insert basket sample weight: 25 ml small quantity of water Medium: Isopropanol and isopropanol-water mixture t = 1–15 min</p>	Cosmetics		Industry
Dissolving	L-10	Deagglomeration of organic substances, e.g. bacterial cultures	<p>Ultrasonic bath: with heater, V = ca. 3 l Liquid in the bath: tap water with TICKOPUR R 33 – 3 % Indirect sonication ▪ Poorly soluble peptides Medium: formic acid Sample vessel: 1,5 ml Eppendorf tubes up to 50 ml Falcon tubes in plastic holders placed into an insert basket t = 1–10 min T = room temperature ▪ buffer Sample vessel: 1-l-laboratory flasks T = room temperature</p>	Biotechnology	Biotechnology	Industry
Dissolving	L-11	Reference substances drugs (hashish, cocaine, etc.) in solvents (coarse-grained)	<p>Ultrasonic bath: without heater Liquid in the bath: Tap water with TICKOPUR R 33 – 3 % Indirect sonication Sample vessel: 10-ml-vials Medium: alcohol t = 10–15 min T = room temperature</p>	Toxicology		Uni/FH/Institut
Dissolving	L-12	standards, buffer (if crystallised)	<p>Ultrasonic bath: without heater Liquid in the bath: Tap water with TICKOPUR R 33 – 3 % Indirect sonication: laboratory flasks placed into an insert basket buffer: 1-l-Laboratory flasks Standards: 10 ml volumetric flasks t = as needed, visual T = room temperature</p>	Analysis and laboratory companies	Pharmacy	Service provider
Dissolving	L-13	Preparations for OC practical course: solids in solvent, especially large crystals	<p>Ultrasonic bath: without heater Liquid in the bath: Tap water with TICKOPUR R 33 – 3 % Indirect sonication Sample vessel: test tubes in a holder placed into an insert basket Medium: ethanol t = 2–3 min T = room temperature up to max. 30/40 °C</p>	Chemistry	Biotechnology	University/institute
Dissolving	L-14	Food samples, food supplements, vitamins in extraction agents	<p>Ultrasonic bath: with heater Liquid in the bath: Tap water with TICKOPUR R 33 – 3 % Indirect sonication Sample vessel: centrifuge vials, volumetric flask (50, 100, 200 ml) in holders or spring clamps EK placed into an insert basket Medium: different, depends on the procedure t = 1–2 min T = 60–70 °C</p>	Analysis and laboratory companies	Foodstuffs	Service provider

Type	No.	Application	Method notes	Working area	Sub-area	Type of company
Dissolving	L-15	Reference substances for determination of PCBs, PAHs etc.	Ultrasonic bath: without heater Liquid in the bath: Tap water with TICKOPUR R 33 – 3 % Indirect sonication Sample vessel: volumetric flask (25 ml), shaking t = 5–10 min T = room temperature	Analysis and laboratory companies		Service provider
Dissolving	L-16	Powder (also unknown substances) in various solvents for analysis HPLC, GC (forensic toxicology)	Ultrasonic bath: DT 1028 F (flat), without heater Liquid in the bath: Tap water with TICKOPUR R 33 – 3 % indirect sonication Medium: different solvents Sample vessel: glass vials (4/ 6/10ml) for HPLC in a holder placed into an insert basket, for GC t = max. 10 min	Toxicology		University/institute
Dissolving	L-17	Food samples, food supplements, vitamins in extraction agents	Ultrasonic bath: with heater Liquid in the bath: Tap water with TICKOPUR R 33 – 3 % Indirect sonication Sample vessel: centrifuge tubes, volumetric flask (50, 100, 200 ml) in a holder placed into an insert basket+ fixing by weighting rings t = 1–2 min T = 60–70 °C	Analysis and laboratory companies	Foodstuffs (vitamins)	Service provider
Dissolving	L-18	Standards (e. g. carotene)	Ultrasonic bath: with heater Liquid in the bath: distilled / deionised water with TICKOPUR R 33 – 1 % Indirect sonication t = some secondes (routine jobs) Remark: Standards crystallise / dissolve immediately when sonicated.	Analysis and laboratory companies		Service provider
Dissolving	L-19	Substances, e.g. caustic soda in water	Ultrasonic bath: without heater Liquid in the bath: Tap water with TICKOPUR R 33 – 3 % Indirect sonication Sample vessel: glass beakers Medium: tap water t = 2–5 min	Toxicology		University/institute
Dissolving	L-20	non-temperature-sensitive solids in organic-aqueous medium (whole tablets - seized goods), dissolving standards in a small bath	Ultrasonic bath: large bath (RK 1028 H), with heater Liquid in the bath: tap water with TICKOPUR TR 3 – 3 % (because of possible risk of contamination) Indirect sonication Sample vessel: test tubes dissolving of tablets solvent: organic/aqueous; do not mortar tablets beforehand because of risk of cross-contamination, not temperature-sensitive T = 2 h–4 h Standard: small ultrasonic bath (RK 100) t = 5–10 min	Toxicology		Public institution
Dissolving	L-21	Substances from the pharmaceutical sector and contract research: biopeptides and small molecules for solubility and stability studies	Ultrasonic bath: with heater Liquid in the bath: Tap water with TICKOPUR R 33 – 3 % Indirect sonication Sample vessel: vials (2 ml) in a "floating" holder t = some seconds up to 30 min T = room temperature, mostly 40 °C	Pharmacy	Biotechnology	Commercial analysis lab

Type	No.	Application	Method notes	Working area	Sub-area	Type of company
Dissolving	L-22	Solids /active pharmaceutical ingredients), lipids	Ultrasonic bath: without heater Liquid in the bath: Tap water with TICKOPUR R 33 – 3 % Indirect sonication Sample vessel: Eppendorf tubes (1–2 ml) t = some seconds up to 5 min	Biotechnology		Industry
Cleaning	R-1	Analysis sieves (small mesh sizes) – residues of chocolate	Ultrasonic bath: RK 106, without heater Liquid in the bath: Tap water with TICKOPUR R 33 – 5 % t = 2 min T = room temperature	Food and luxury food industry	Confectionery	Industry
Cleaning	R-2	MS source	Ultrasonic bath: long and narrow, without heater Liquid in the bath: Tap water with TICKOPUR R 33 – 3 % Indirect sonication Gefäße: glass beakers, inset tubs Medium: methanol	Toxicology	Analysis laboratory for medicine	Öffentliche Einrichtung
Cleaning	R-3	MS source, other lab equipment made of glass	Bad: with heater Liquid in the bath: Wasser with TICKOPUR R 33– 5 % Vessels: glass beakers, plastic inset tubs	Toxicology		Public institution
Cleaning	R-4	MS source, spray units	Bad: with heater Liquid in the bath: Tap water with TICKOPUR R 33 – 3 % Indirect sonication Vessel: glass beakers, inset tubs Medium: acetone/ethanol Remark: Disassemble MS source -> rub with aluminium oxide -> rinsing 2 x with DI water -> indirect cleaning with solvent in ultrasonic bath -> rinsing with DI water	Cosmetics		Industry
Cleaning	R-5	Quartz beakers, PTFE-containing glass -removing residues from cutting/ saw blade	Ultrasonic bath: round, without heater Liquid in the bath: Tap water with TICKOPUR R 33 – 3 % Indirect sonication Indirect cleaning in an inset tub Medium: diluted nitric acid t = 15 min T = room temperature			
Cleaning	R-6	MS source	Ultrasonic bath: without heater Liquid in the bath: Tap water with TICKOPUR R 33 – 3 % Indirect sonication Vessels: glass beakers, inset tubs Medium: ethanol/methanol	Biotechnology		Industry
Cleaning	R-8	Lab glassware	Ultrasonic bath: oblong, with heater Liquid in the bath: Tap water with TICKOPUR R 33 – 3 % Indirect sonication Vessels: Glass beakers Medium: ethanol, methanol	Analysis and laboratory companies	Environment, Chemistry, Pharmacy	Service provider
Cleaning	R-9	Analysis sieves (subsoil samples, soil, clays) - particle size analysis	Ultrasonic bath: round, without heater Liquid in the bath: Tap water with TICKOPUR R 33 – 3 % Indirect sonication: according to EN ISO 17892-4 for particle size analysis) t = 15 min–2 h particle sizes: 0–0,125 µm (platelet particles, some of them tilted). Dispersing agent (disodium dihydrogen pyrophosphate) ▪ sieves with larger mesh sizes: cleaning by brush	Analysis and laboratory companies	Environment (soils, construction projects)	Service provider

Type	No.	Application	Method notes	Working area	Sub-area	Type of company
Cleaning	R-10	Analysis sieves	Ultrasonic bath: rectangular area, with heater Liquid in the bath: Tap water with TICKOPUR R 33 – 5 % Contamination: feed cleaning in an insert basket t = 5 min	Environmental analysis and technology		Service provider
Cleaning	R-11	Fermenter parts from sticky biofilms, e.g. stirrer shafts - caked after autoclaving	Ultrasonic bath: with heater Liquid in the bath: Tap water with TICKOPUR R 33 – 5 % Vessels: Glass beakers filled with water: for small parts, otherwise direct cleaning in an insert basket t = max.1 h visual check T = room temperature	Biotechnology		University/institute
Cleaning	R-12	MS source	Ultrasonic bath: RK 100, without heater Liquid in the bath: Tap water with TICKOPUR R 33 – 3 % Indirect sonication Vessels: plastic inset tub Medium: 1. water/methanol (+1- bis 3 % formic acid), 2. methanol, 3. isopropanol (very clean!)	Analysis and laboratory companies		University/institute
Cleaning	R-13	Lab equipment	Ultrasonic bath: with heater Liquid in the bath: Tap water with TICKOPUR R 33 – 5 % Contamination: oily residues t = 5 min T = 40/50 °C	Medicine/Veterinary medicine	Biotechnology	Hospital
Cleaning	R-14	Analysis sieves – residues from sedimentation of soil	Ultrasonic bath: RK 1028, without heater Liquid in the bath: distilled / deionised water with TICKOPUR R 33 – 1 %			
Cleaning	R-15	Burettes after Titration	Ultrasonic bath: without heater Liquid in the bath: Tap water with TICKOPUR R 33 – 5 % Contamination: acid/alkali residues t = some minutes Remark: Rinse burettes first	Pharmacy		Industry
Cleaning	R-16	Ultra-Turrax / rods	Ultrasonic bath: with heater Liquid in the bath: tapwater with TICKOPUR TR 13 – 5 % T = approx. 50 °C t = some minutes	Food and luxury food industry		Laboratory for foodstuffs
Cleaning	R-17	Lab equipment: Parts made of glass/ stainless steel	Ultrasonic bath: without heater Liquid in the bath: Tap water with TICKOPUR R 33 – 3 % Indirect sonication Vessels: glass beakers Medium: water, alcohols t = some minutes T = room temperature	Biotechnology	Biotechnology	Industry
Cleaning	R-18	Glass labware – sticky residues	Ultrasonic bath: with heater: Liquid in the bath: tap water TICKOPUR R 27 – 1 % t = some minutes T = approx.. 50 °C	Biotechnology		University/institute
Cleaning	R-20	MS source (LC-MS)	Ultrasonic bath: rectangular, with heater Liquid in the bath: distilled / deionised water with TICKOPUR R 33 – 1 % Vessels: glass beakers placed into the insert basket Medium: DI water and/or solvent	Toxicology	Analysis laboratory for medicine	Public institution

Type	No.	Application	Method notes	Working area	Sub-area	Type of company
Cleaning	R-19	MS source (GC-MS)	Ultrasonic bath: RK 100, without heater Liquid in the bath: distilled / deionised water with TICKOPUR R 33 – 1 % Medium: alcohol (methanol, ethanol) t = 15 min T = room temperature	Toxikology		University/ institute
Cleaning	R-21	Loops required for crystallisation of proteins (crystallisation lab). (Use: protein crystals from aqueous solution for X-ray structure analysis. Röntgenstrukturanalyse)	Ultrasonic bath: with heater Liquid in the bath: Tap water with TICKOPUR R 27 – 5 % t = approx. 5 min T = approx. 50 °C	Biotechnology		University/ institute
Cleaning	R-22	Sieves with baking powder	Ultrasonic bath: without heater Liquid in the bath: Tap water with TICKOPUR R 33 – 5 % cleaning in a sieve holder or an insert basket t = 5 min	Food and luxury food industry	Baking agents	Industry
Cleaning	R-23	Clogged small parts from paper machines, removing of dirty films of metal parts, e.g. after flue gas measurement, removing of manufacturing aids	Ultrasonic bath: narrow, without heater Liquid in the bath: Tap water with TICKOPUR R 33 – 5 % Indirect sonication Gefäße: Glass beakers for small parts Medium: Indirect cleaning: water with acetone R 33-solution: direct cleaning in an insert basket t = 20 min T = room temperature			
Cleaning	R-24	Ceramic balls from a laboratory mill; lab equipment	Ultrasonic bath: small, with heater Liquid in the bath: Tap water with TICKOPUR R 33 – 3 % Indirect sonication Gefäße: Glass beakers with contaminated parts Medium: water with soapy water, sometimes ethanol use t = 30 min T = room temperature	Toxikologie		University/ institute
Cleaning	R-25	Sieves: removing of silver powder and ash containing precious metals (loose); non-fusible (determination of particle size), electrodes, capillaries, small tubes	Ultrasonic bath: narrow, with heater Liquid in the bath: Tap water with TICKOPUR R 33 – 3 % Indirect sonication Gefäße: Glass beakers Medium: water without additives t = some minutes T = room temperature	Metal processing		Industry
Cleaning	R-26	Decontamination of samples: cleaning of hair samples from adhering surface contaminants	Ultrasonic bath: with heater Liquid in the bath: Tap water with TICKOPUR R 33 – 3 % Indirect sonication Sample vessel: 10 ml glass vessel Different solvents t = 5 min	Toxikology		Public institution
Zellyse	Z-1	Eukaryotic cells of various mammals (mouse to human, primary cells, tumour cells), but no fungi, no yeast, in addition to lysis (lysis with and without detergent,) – ultrasonic treatment for safety	Ultrasonic bath: rectangular Liquid in the bath: distilled / deionised water with TICKOPUR R 33 – 1 % Vessels: Eppendorf tubes Medium: aqueous solutions, buffer, detergent, inhibitors, "cell soup" + detergent 1. with detergent 2. without detergent, (common salt, utilisation of osmotic pressure).	Pharmacy	Biotechnology	University/ institute

FAQ - Ultrasonic baths

Can I fill the bath with drinking water or distilled water if I don't want to clean anything, but want to sonicate vessels?

No, please use drinking water with the addition of an ultrasound-compatible cleaning agent always, to reduce the surface tension. This contributes to the even propagation of the ultrasonic waves and extends the lifespan of the stainless steel tank.

Can I place vessels such as 1L glass bottles on the bottom of the oscillating tank during sonication?

No! This would significantly shorten the lifespan of the tank. Above all, the ultrasonic waves can only propagate properly if there is at least 1 cm of liquid phase between the tank bottom and the bottom of the vessel. Damage to the glass vessel is also possible.

How often does the bath liquid need to be changed?

If the cleaning performance deteriorates or if there is visibly heavy soiling.

This depends on the number of parts to be cleaned and the type of contamination. If the bath liquid is too heavily contaminated, the cleaning power will be reduced.

Can I reach into the bath liquid during operation?

No, this can damage the bone tissue.

Can ultrasound damage the parts?

Thousands of very powerful implosions occur every second. Nevertheless, cleaning with ultrasound is a safe procedure because the energy is found at a microscopically small level.

Is rinsing required after cleaning?

Yes, to remove chemical residues. During removal of the objects to be cleaned, bath liquid residues or dissolved contamination particles remain on their surfaces. The objects can be rinsed in another ultrasonic or rinsing bath, as well as under running drinking water. A final rinse in DI water is recommended for stain-free parts surfaces.

Is it necessary to degas prior to the sonication process?

Yes, for a few minutes up to half an hour (depending on bath size) in order to expel dissolved air bubbles. Otherwise, these would have a disruptive effect on the process. The degassing process ends when the sound changes and becomes quieter and less shrill.

Is hearing protection necessary?

Yes, for continuous work within a radius of 2 m.

Can small parts be stacked/layered during cleaning?

No, shadowing effects may occur here despite propagation of the ultrasound throughout the bath fluid. This means that the ultrasound intensity on the sample is not sufficient to trigger cavitation. The cleaning effect is not satisfactory.

Are there alternatives if the power input in the ultrasonic bath does not yet produce the desired effect?

If the desired results are not yet achieved, the test with the SONOPULS ultrasonic homogenisers is recommended, as the energy input into the sample matrix with the liquid is significantly higher. On the one hand, the power density is up to 3000 W/L compared to up to 50 W/L for the ultrasonic bath and, on the other hand, the homogenisers work with 20 kHz. The lower the frequency, the more intense the cavitation. Please refer to the corresponding application guide "SONOPULS ultrasonic homogenisers" or contact us for a consultation and free trial use of two weeks.



Your contact person for the laboratory field

We will pleased to advice you.



Dipl.-Ing.
Marina Herrmann

Sales manager
Laboratory ultrasound

 +49 30 76880-18

marina.herrmann@bandelin.com

Contact

Address:

BANDELIN electronic
GmbH & Co. KG
Heinrichstraße 3 – 4
12207 Berlin
DEUTSCHLAND

 +49 30 76880-0

 +49 30 7734699

info@bandelin.com

www.bandelin.com

Visit us on social media:



Made in Germany

BANDELIN electronic
GmbH & Co. KG
Heinrichstraße 3 – 4
12207 Berlin
GERMANY
☎ +49 30 76880-0
☎ +49 30 7734699
✉ info@bandelin.com

Certified in accordance with
ISO 9001 and ISO 13485



Tell us your requirements –
We will be pleased to advise you at no obligation.

+49 30 76880-0

www.bandelin.com



51092-004 en/2023-09

Subject to technical alterations without notice.

Dimensions subject to production tolerances.

Illustrations exemplary, not true to scale.

Decoration products are not included in delivery.

The General Business Terms and Conditions apply.

Photos partly from: www.der-gottwald.de.